



MXA320

Table Array Microphone

Shure MXA320 table array microphone manual. Learn how to steer mic coverage, set up onboard IntelliMix DSP, and get premium sound for AV conferencing
Version: 0.3 (2026-B)

Table of Contents

MXA320 Table Array Microphone	4	Parametric Equalizer	30
MXA320 Overview	4	Mute Points in Control Software	33
Getting Started	4	Automix Channel	34
Videoconferencing Room Equipment	4	Automix Settings	35
MXA320 Designer Setup Example	5	Automix Modes	36
MXA320 Web Application Setup Example	9	Speech Gating Threshold	37
MXA320 Parts	13	Mute Sync	38
LED Light Ring	14	IntelliMix DSP	39
Mute Buttons	14	DSP Best Practices	39
Power Over Ethernet (PoE)	15	Acoustic Echo Cancellation (AEC)	39
Dante Channels	15	Noise Reduction	40
What's in the Box	16	Automatic Gain Control (AGC)	41
Reset Button	16	Delay	41
MXA320 Control Software	17	Compressor	41
Firmware Updates	17	Use Presets	42
Manage Devices in ShureCloud	17	Security	42
Microphone Coverage	17	Encryption	42
Use Coverage Templates	19	Set Up the 802.1X Protocol for a Device	42
Change a Lobe's Polar Pattern	19	Networking	44
Polar Pattern Options	20	Networking Best Practices	44
How to Install the MXA320	21	Switch and Cable Recommendations for Dante Network- ing	44
Table Installation	22	Device IP Configuration	45
Install the Cable-Exit Plug	27	Setting Latency	45
Use Designer's Auto Route	27	QoS (Quality of Service) Settings	45
Adjust Levels	28	Ports, Protocols, and Firewall Rules	46
Direct Out Tap Points	30	Digital Audio Networking	46
EQ Contour	30	AES67	47
		Use Command Strings	48

Troubleshooting	48	Explanation of Symbols	55
Additional Resources	49	Important Safety Instructions	56
MXA320 Specifications	50	Important Product Regulatory Information	57
MXA320 Frequency Response	51	Introduction to EMC	59
Polar Patterns	52	Regulatory Model Number (RMN)	59
MXA320 Dimensions	55		

MXA320 Table Array Microphone

MXA320 Overview

The Microflex® Advance™ MXA320 is a premium networked table array microphone, designed for AV conferencing. Featuring onboard IntelliMix® DSP and enhanced Steerable Coverage™ technology lobe accuracy for improved directional audio capture, the MXA320 offers better rejection of ambient room noise and streamlined configuration. With deployment aided by updated Designer software, remote monitoring via ShureCloud and certification with leading third-party collaboration platforms, the MXA320 delivers exceptional clarity and intelligibility for AV conferencing in any space.

Getting Started

Videoconferencing Room Equipment

Your Microflex microphone is one part of a complete room system for videoconferencing. It's helpful to think about all the parts of your room system as you get started setting up the microphone.

A standard room includes some or all of this equipment:

- Microphone(s)
- DSP or other processor
- Loudspeakers (networked or analog)
- Computer with videoconferencing software
- Network switch
- Camera
- Other accessories such as table mute buttons, tablets to control meetings, and other peripherals



Small room equipment example

The [Microflex Ecosystem](#) offers a complete portfolio of networked audio solutions that can be precisely tailored to your needs.

What Software Do I Need to Set Up This Microphone?

Install this software on a computer that connects to the same network as the microphone:

- Control software to adjust microphone settings. This microphone has 2 options:

Option 1: [Shure Designer](#)

- Use for managing lots of Shure devices in 1 place
- Control Shure devices and route audio between them
- Create rooms to manage devices and design coverage

Option 2: Web application (open using [Shure Update Utility](#))

- Use to manage each Shure device separately
- Control each device individually with its web application
- Route audio using [Dante Controller](#)
- **Dante Controller** to send audio signals to other Dante devices. Not necessary if you're only routing audio to Shure devices in Designer.
- **Shure Update Utility** to update firmware on Shure devices and open device web applications (download at shure.com/suu)

MXA320 Designer Setup Example

This example uses Shure Designer software to set up 2 MXA320s, a [P300 audio conferencing processor](#), and 2 [MXN-6 loudspeakers](#).

You might use Designer if:

- You're managing many Shure devices across many rooms
- You're routing audio between groups of Shure devices

The process is similar when using other combinations of devices, so use these steps as a starting point.

After completing this setup process, you should be able to:

- Access MXA320 settings in Designer
- Steer microphone coverage
- Route audio and adjust DSP settings
- Turn on mute sync between the MXA320s and the videoconferencing software

This example uses:

- Cat5e (or better) Ethernet cable
- [Network switch](#) that provides Power over Ethernet Plus (PoE+)
- Computer with Designer (download at shure.com/designer)
- Computer with videoconferencing software
- P300 audio conferencing processor
- 2 MXN-6 loudspeakers

Step 1: Install and Connect

1. Before installing devices, plan out coverage for the room.
 - Learn about [MXA320 coverage](#) and polar patterns. The polar pattern influences channel routing (see [Automix Channel](#) for details).
 - [Use design rooms](#) to experiment with mic and loudspeaker coverage before installation.
 - Consider future seating needs or room configurations.
2. [Install the MXA320s](#) and other devices. Connect devices to the switch with Ethernet cable:
 - P300 requires PoE+
 - MXN-6 can use PoE or PoE+
 - MXA320 requires PoE

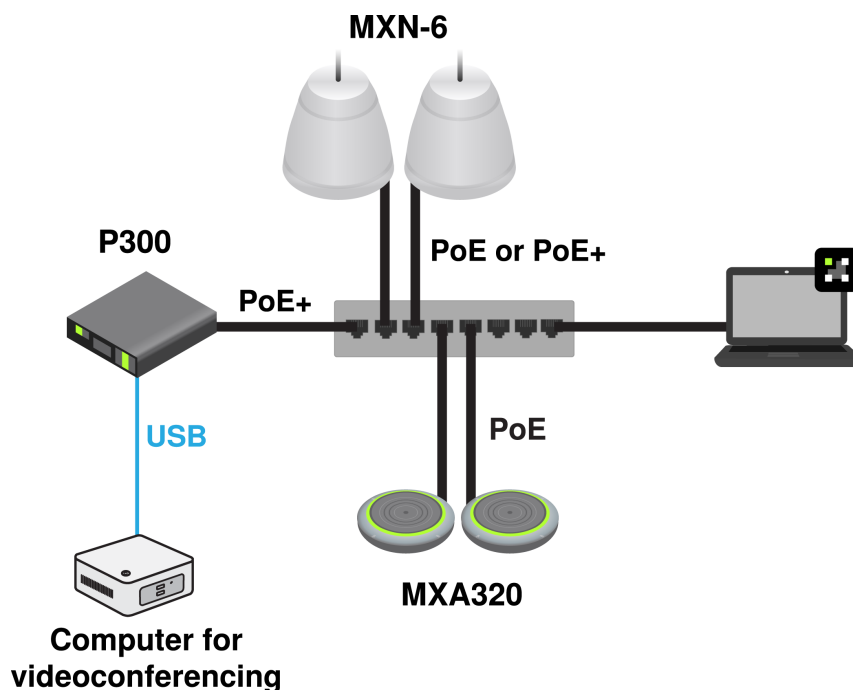

3. Connect the computer with videoconferencing software (such as Zoom or Microsoft Teams) to the P300 using USB cable.
4. Connect the computer running Designer to the same network.
5. Open Designer. Check that you're connected to the same network as the devices in **File > Designer preferences**.
6. Create a new online room. Drag the devices into the room from the **Devices** panel.
 - The **Routing** and **Coverage** views show all devices in the room.
 - Double-click a device to open its settings in a new tab.

Step 2: Adjust Coverage

Adjust coverage for the MXA320s before routing audio.

1. Go to [Your room] > **Coverage**.
 - Rotate the MXA320s in Designer to match your installation. Use the Shure logo (0°) as a reference point.
 - Use the **Properties** panel to space the 2 mics as they are installed in the room.
 - To start with a coverage template, select a mic and go to **Properties > Coverage > Templates**. The default pattern is 4 cardioid channels.
2. Steer the lobes to cover the seating areas. For a table with 2 MXA320s using separate channels, delete the 2 lobes pointed at each other in the middle of the table.

Skip this step if you're using omnidirectional or toroid polar patterns.

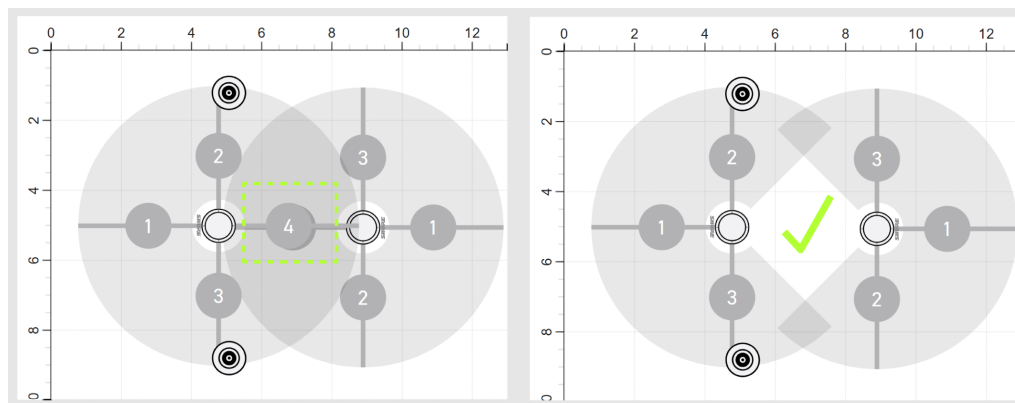

When you have a good starting point for coverage, move on to step 3.

Tip: Set the light ring to use segments in **Settings > Lights** to help see where each channel is aimed. The ID option in the Properties panel can help you identify channels on each mic.

Step 3: Run Designer's Auto Route

The auto route feature is the easiest way to route audio signals, apply DSP settings, turn on mute sync, and enable LED control for connected devices.

1. In your online room, select Auto route. Designer makes the following routes:

- MXA320 to P300 inputs
- P300 output to MXN-6s and MXA320 AEC reference channels
- P300 USB input/output to computer with videoconferencing software

You can also route audio manually in Designer or use Dante Controller.

Important: Always route an AEC reference signal to the MXA320, even if a separate DSP is handling acoustic echo cancellation.

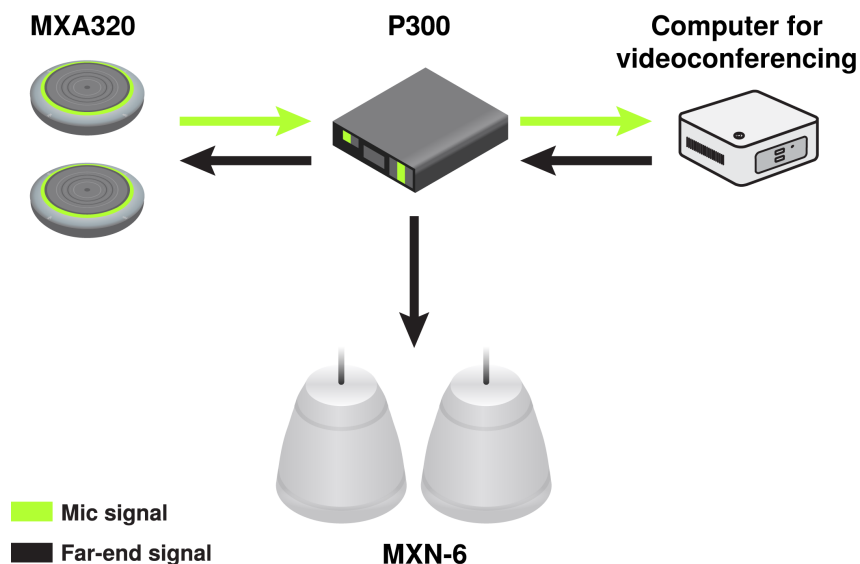

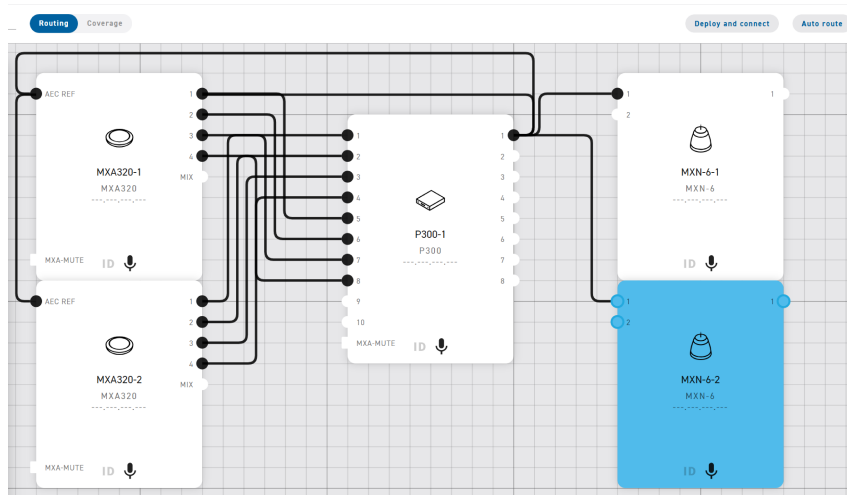

Designer's routing view

2. Auto route sets up [mute sync](#) between the mics, DSP, and videoconferencing software. For this group of devices, that means:
 - Pressing 1 MXA320's mute button mutes or unmutes the P300's automix output. The mics and videoconferencing software reflect the mute status.
 - MXA320s are set to Logic out and P300 has Mute sync and Logic turned on.
 - [Learn more about MXA320 logic control settings.](#)
3. Check the audio routes, P300 matrix mixer routes, and other settings to make sure they fit your needs. The auto route process selects the MXA320s to do DSP processing in this example.

Note: Avoid duplicating DSP processing. Learn more in the [IntelliMix DSP section](#).

Step 4: Test System and Adjust

Make a test call to someone else and adjust coverage and settings as needed.

1. Open the videoconferencing software on the computer connected to the P300. In the settings, choose the P300 as the speaker and microphone.
2. Place a test call to someone else and have the other person tell you how the microphones sound. Make gain, EQ, or DSP adjustments in each MXA320's device tab.
3. Test the mute button behavior. Pressing mute on one MXA320 should mute the P300's automix output and both MXA320s should show the same mute status.
4. To adjust mic coverage, go to the room's Coverage tab.

MXA320 Web Application Setup Example

This example uses device web applications and Dante Controller to set up an MXA320 and an [ANIUSB-MATRIX](#). You might use web applications and Dante Controller if:

- You don't have many Shure devices to manage
- You need to route audio to third-party Dante devices

The process is similar when using other combinations of devices, so use these steps as a starting point.

After completing this basic setup process, you should be able to:

- Open the MXA320's web application

- Route audio and adjust DSP settings
- Steer microphone coverage
- Understand the basic workflow for working with device web applications and Dante Controller

This example uses:

- Cat5e (or better) Ethernet cable
- [Network switch](#) that provides Power over Ethernet (PoE)
- Computer with [Shure Update Utility](#) and [Dante Controller](#) software
- Computer with videoconferencing software
- ANIUSB-MATRIX

Step 1: Install and Connect

1. Before installing devices, plan out coverage for the room.
 - Learn about [MXA320 coverage](#) and polar patterns. The polar pattern influences channel routing (see [Automix Channel](#) for details).
 - Consider future seating needs or room configurations
2. [Install the MXA320](#) and other devices. Connect devices to the switch with Ethernet cable.
3. Connect the computer with videoconferencing software (such as Zoom or Microsoft Teams) to the ANIUSB-MATRIX using USB cable.
4. Connect a computer with Shure Update Utility and Dante Controller software to the same network.

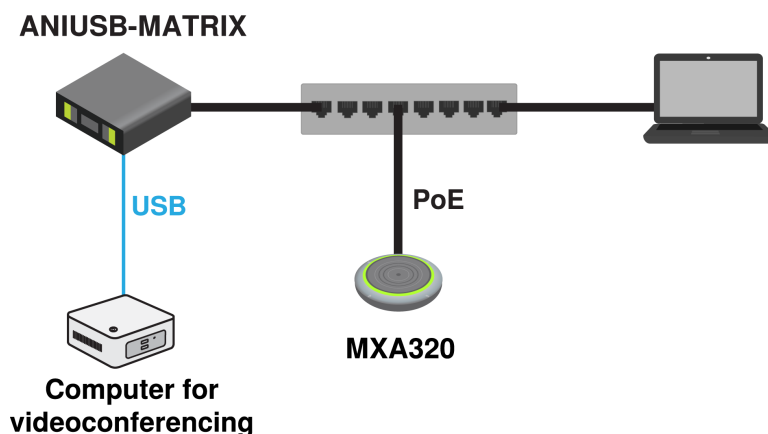

5. Open Shure Update Utility. Find the MXA320 and ANIUSB-MATRIX in the list of online devices and double-click to open their web applications. Each one opens in a separate browser tab.

Step 2: Adjust Coverage

Adjust coverage for the MXA320 before routing audio.

1. In the MXA320's web application, go to Coverage.
 - Rotate the MXA320 to match your installation. Use the Shure logo (0°) as a reference point.
 - To start with a coverage template, select the mic and go to **Properties > Coverage > Templates**.
2. Steer the lobes to cover the seating areas. When you have a good starting point for coverage, move on to step 3.

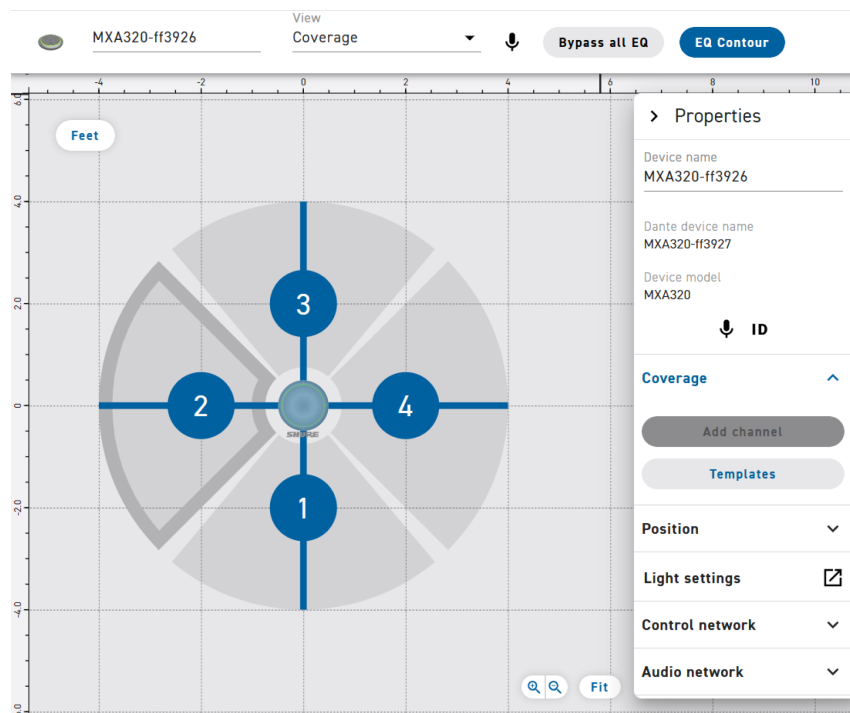

MXA320 coverage view in web application

Step 3: Route Audio

Use Dante Controller to route audio to and from other Dante devices. We'll route the MXA320's microphone signal to an ANIUSB-MATRIX for this example.

1. Open Dante Controller. Check that you're connected to the correct network interface. Find both devices in the list of transmitters and receivers.
2. Make these routes:
 - MXA320 automix output to ANIUSB-MATRIX input
 - ANIUSB-MATRIX output to MXA320 AEC reference input. The AEC reference signal is usually the same one that feeds the room's loudspeakers.

Important: Always route an AEC reference signal to the MXA320, even if a separate DSP is handling acoustic echo cancellation.

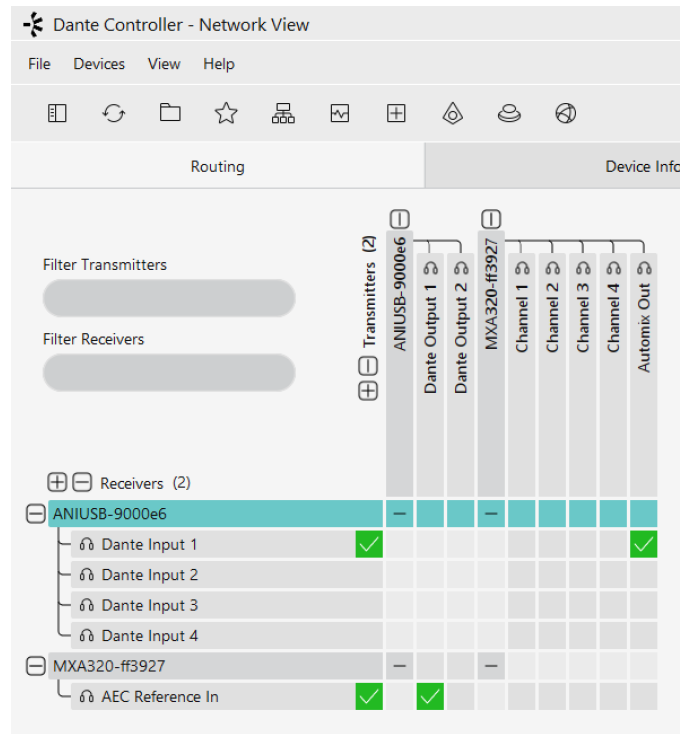

Dante Controller routes for MXA320 and ANIUSB-MATRIX

- Send audio from the ANIUSB-MATRIX to the computer with videoconferencing software using the ANIUSB-MATRIX's matrix mixer. Open the ANIUSB-MATRIX web application. Make sure the Dante input is routed to the USB output.

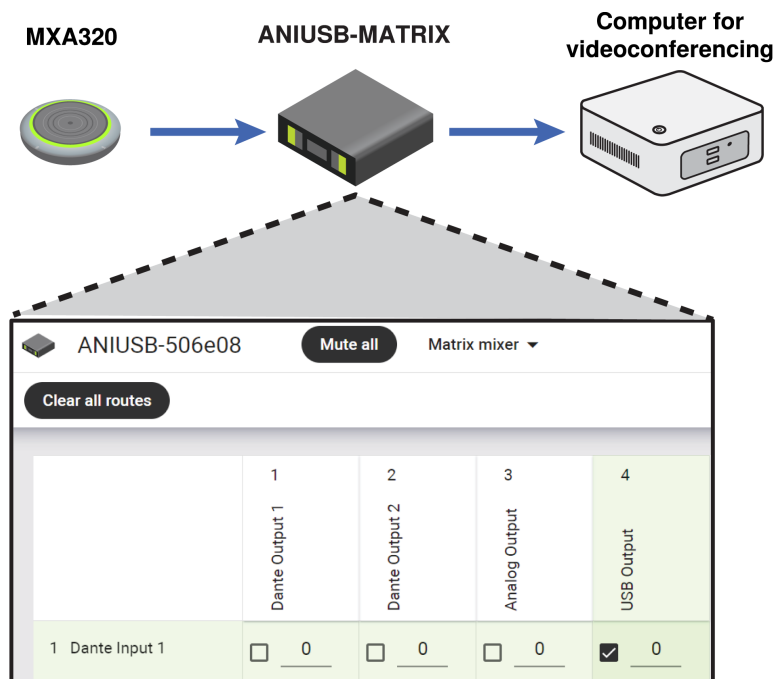

- In your videoconferencing software, select the ANIUSB-MATRIX as the microphone and loudspeaker source.

Step 4: Listen and Adjust

1. Place a test call with the entire system and have the far-end caller tell you how your microphone signal sounds. Make gain, EQ, or DSP adjustments in the MXA320's web application.
2. If needed, move the lobes in the Coverage tab.

MXA320 Parts

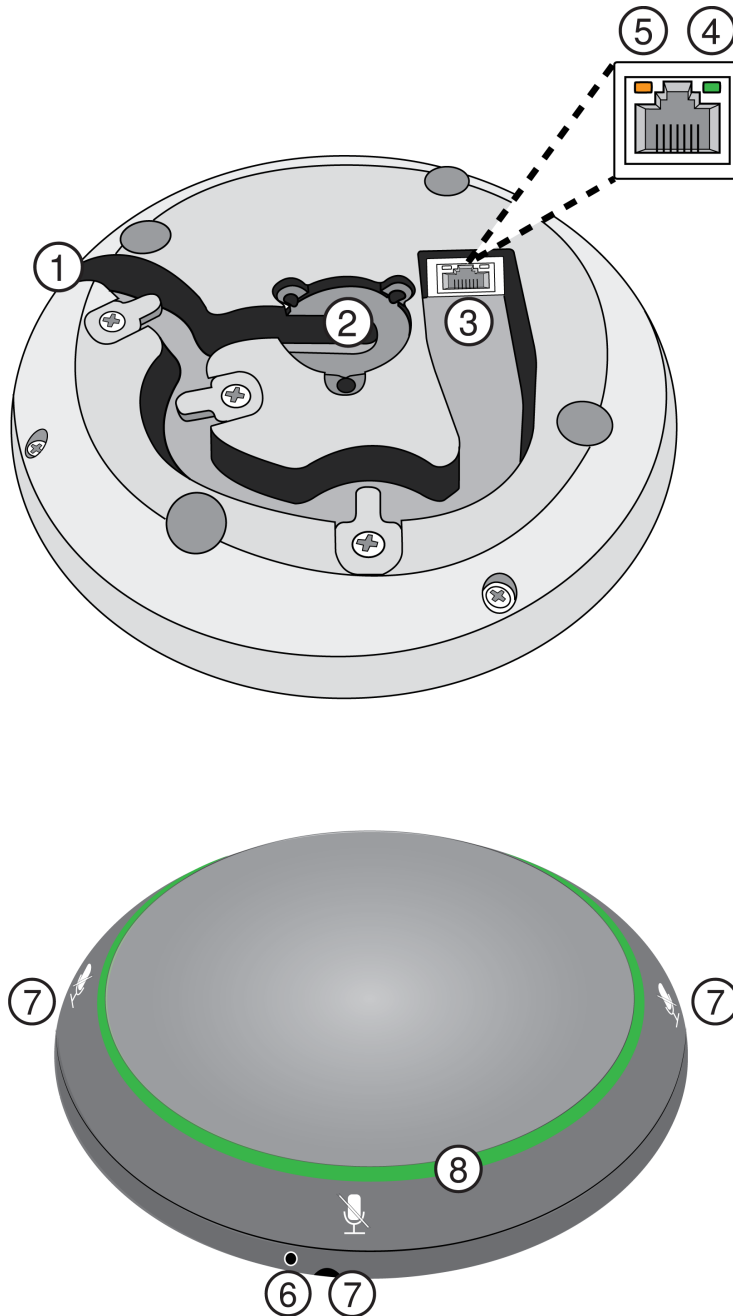

1. Cable exit
2. Bottom cable exit

Note: Use the cable plug accessory when the cable is routed through the bottom.

3. RJ-45 network port
4. Network status LED (green)
 - Off = No network link
 - On = Network link established
 - Flashing = Network link active
5. Network speed LED (amber)
 - Off = 10/100 Mbps
 - On = 1 Gbps
6. Reset button
7. Touch-sensitive mute buttons
8. LED light ring

LED Light Ring

To change light ring settings, go to **Settings > Lights** in Designer or the device web application.

MXA320 LED Default Settings

Microphone Status	LED Behavior
Active	Green solid
Mute	Red solid
Hardware identification	Green flashing Device identify: Entire light ring Channel identify: Light ring segment
Firmware update in progress	Green (ring fills up, turns off, repeats)
Reset	Network reset: Red rotates around ring Factory reset: LED turns off, white mute icons flash, then blue rotates around ring
Error	Red (split, alternate flashing). See the event log in the control software for details.
Device power-up	Blue rotates around ring

Mute Buttons

The microphone has 4 touch-sensitive mute buttons around the edge of the microphone. Pressing any button mutes the entire device.

You can mute channels individually using Shure Designer software or the web application.

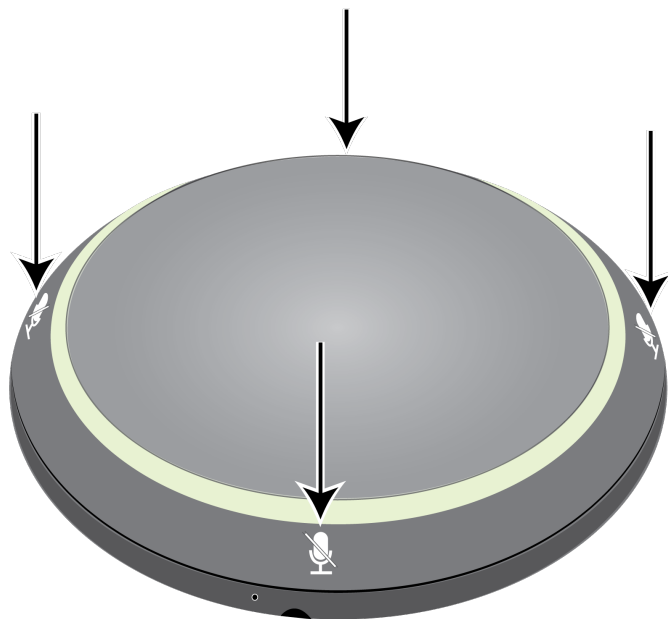

To adjust button properties in Designer or the web application, go to **Settings > Logic control**.

Mute Control Function

- **Local:** Mutes/unmutes the device. Use when you want to mute 1 microphone in a room.
- **Logic out:** Use for [mute sync](#) (when you want all MXA320s in a room to show the same mute state). The mic sends a command string to trigger muting at the processor's output.
- **Disabled:** Button is inactive

Mute Control Mode

- **Toggle on/off:** Press the button to switch between muted and unmuted states.
- **Push to talk:** Hold the button to activate the microphone when speaking.
- **Push to mute:** Hold the button to mute the microphone.

Default Toggle State

Determines whether the microphone is muted or unmuted when powered on

Power Over Ethernet (PoE)

This device requires PoE to operate. It is compatible with both **Class 0** and **Class 2** PoE sources.

Power over Ethernet is delivered in one of the following ways:

- A network switch that provides PoE
- A PoE injector device

Dante Channels

The MXA320 has 6 total channels:

- Up to 4 direct output channels that correspond to the microphone's steerable lobes

- 1 automix output with IntelliMix DSP
- 1 AEC reference input

What's in the Box

MXA320 Included Parts

Cable-exit plug (black)	65A29429
Cable-exit plug (white)	65B29429
Cable-exit plug (silver)	65C29429
Mounting tube wing nut	65A27351
Mounting tube	31A2165
Rubber washer (2)	66A405
Nylon cable ties (2)	80A583

Reset Button

The reset button is located inside a small hole in the lower half of the microphone. Use a paperclip or other small tool to press the button.

You can also use the control software to reset the device.

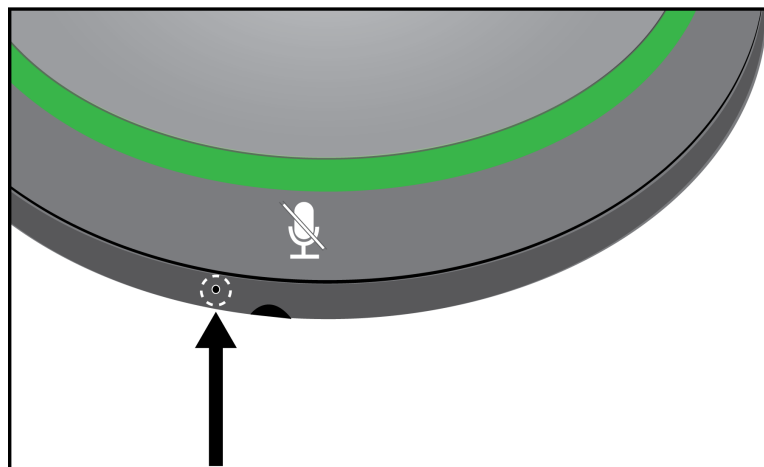

Reset Modes

- **Network reset (press button for 4-8 seconds):** Resets all Shure control and audio network IP settings to factory defaults. Red LED rotates around ring.
- **Full factory reset (press button for longer than 8 seconds):** Restores all network and configuration settings to the factory defaults. LED turns off, white mute icons flash, then blue rotates around ring.

MXA320 Control Software

There are 2 ways to control the MXA320:

1. Use [Shure Designer software](#)
 - Control all Shure devices in one place
 - Route audio to and from Shure devices
2. Use the MXA320's built-in web application (open with [Shure Update Utility](#))
 - Control 1 microphone at a time
 - To route audio, use [Dante Controller software](#)

Firmware Updates

Firmware is embedded software in each component that controls functionality. Periodically, new versions of firmware are developed to incorporate additional features and enhancements. You can install firmware using Shure Update Utility.

Download Shure Update Utility at shure.com.

Manage Devices in ShureCloud

Use [ShureCloud](#) to remotely view information about supported devices.

Refer to the ShureCloud user guide to learn [how to add devices to your ShureCloud account](#).

Microphone Coverage

The MXA320 has 4 channels that can be aimed independently to fit the seating arrangement. Each channel has independent polar patterns, input gain, and PEQ which you can control with Designer or the web application.

Tip: If you're using a non-directional polar pattern (toroid or omnidirectional), you should remove directional channels unless they are specifically needed for your use case. [Learn more about automixer behavior](#) when there is a mix of directional and non-directional channels.

What is the MXA320's Coverage Area?

The MXA320 performs best when all talkers can easily reach the mute button. Talkers should be 2-3 feet from the center of microphone (0.6-0.9 m), and no more than 4 feet (1.2 m).

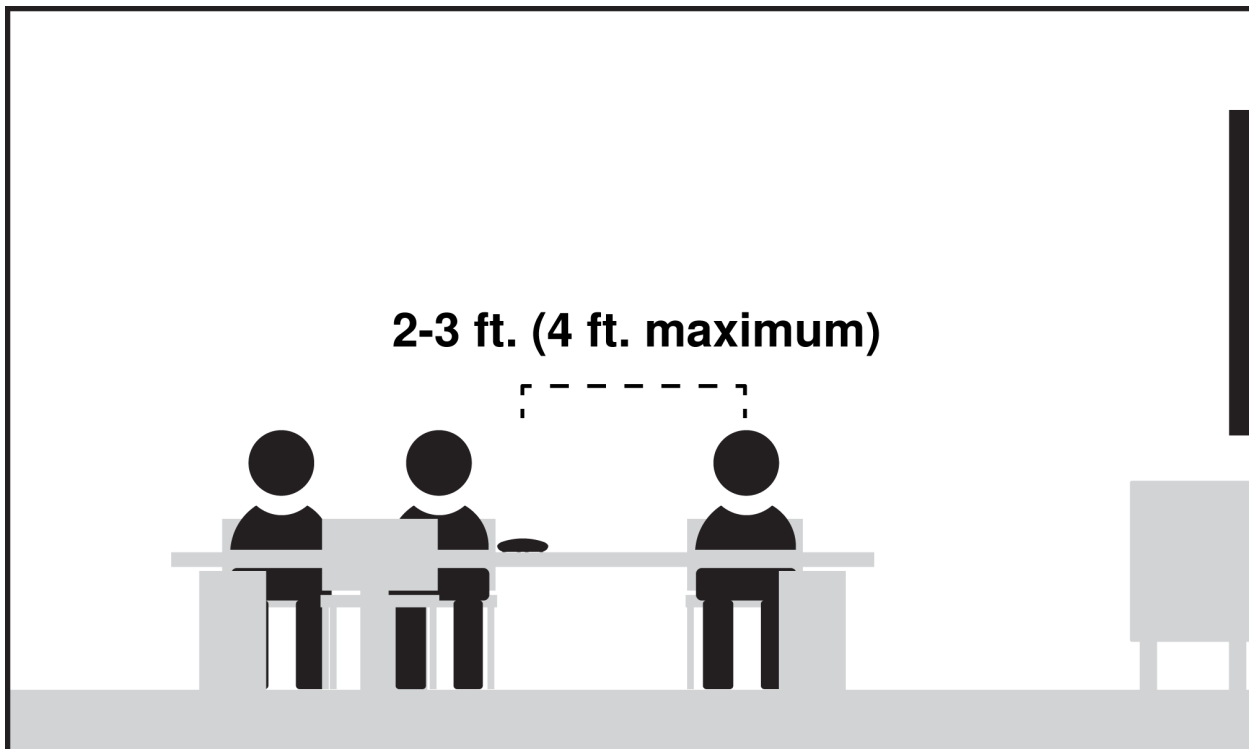

The darker gray circle shows 4 feet from the mic's center as the edge of the coverage area in the control software.

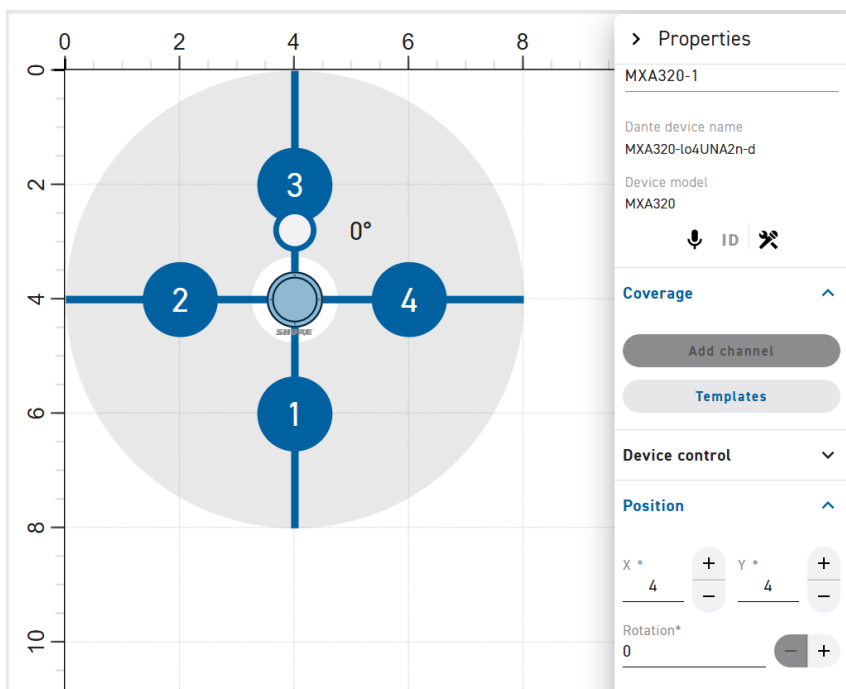

How to Steer Coverage

Use Designer or the device web application to position microphone coverage. Click and drag each channel to steer coverage around the microphone in 15° increments.

For accuracy, rotate the MXA320 in the control software to match how it is installed in the room. You can use the ID button in the Properties panel to help identify a channel.

Tips for Rooms with Multiple MXA320s

- Decide on your desired mute behavior:
 - Press mute on 1 MXA320 to mute all mics in room:** Set up [mute sync](#) with a Shure DSP. MXA320s should have the Mute control function set to Logic out.
 - Press mute on 1 MXA320 to mute that mic only:** MXA320s should have the Mute control function set to Local.
- If all mics are on the same table and you're using directional polar patterns, delete the lobes pointed at each other in the center of the table. See step 2 in the [Designer Setup Example](#) for details.
- Route microphone signals to a processor with an automixer. The automixer mixes the signal from each MXA320 based on who is talking.
 - Shure options: P300 or a PC with IntelliMix Room software
 - The ANIUSB-MATRIX works best with 1 microphone because it doesn't have an automixer.
- Route an AEC reference signal to each microphone.

Use Coverage Templates

Use a coverage template as a starting point for setting up microphone coverage. Templates only adjust coverage and do not affect gain levels or other settings.

To use a coverage template:

- In Designer or the web application, go to Coverage and select a microphone.
- Open the Properties panel and go to Coverage > Templates.
- After applying the template, add, delete, or move the lobes as needed.

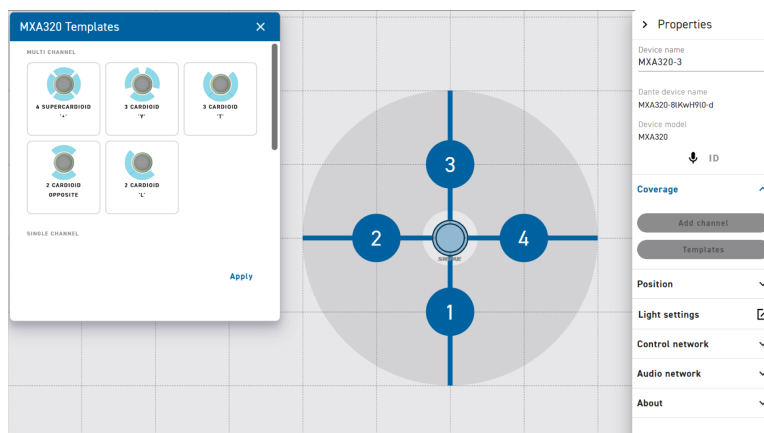

MXA320 template options

Change a Lobe's Polar Pattern

You can change lobe polar patterns in Designer or the embedded web application. The polar pattern determines the shape and character of the microphone's coverage.

Each of the 4 lobes can use their own polar pattern. For example, you could use 2 cardioid channels and 2 supercardioid channels. When you use toroid or omnidirectional patterns, it's most common to use only 1 channel.

To change a lobe's polar pattern:

- In Designer or the web application, go to the room's Coverage section.
- Select one of the 4 channels and go to Properties. Choose a polar pattern from the menu.

Note: You can also change polar patterns in the MXA320's coverage view. Double-click the mic and go to [View > Coverage](#). Then select a channel and go to [Properties > Lobe control](#).

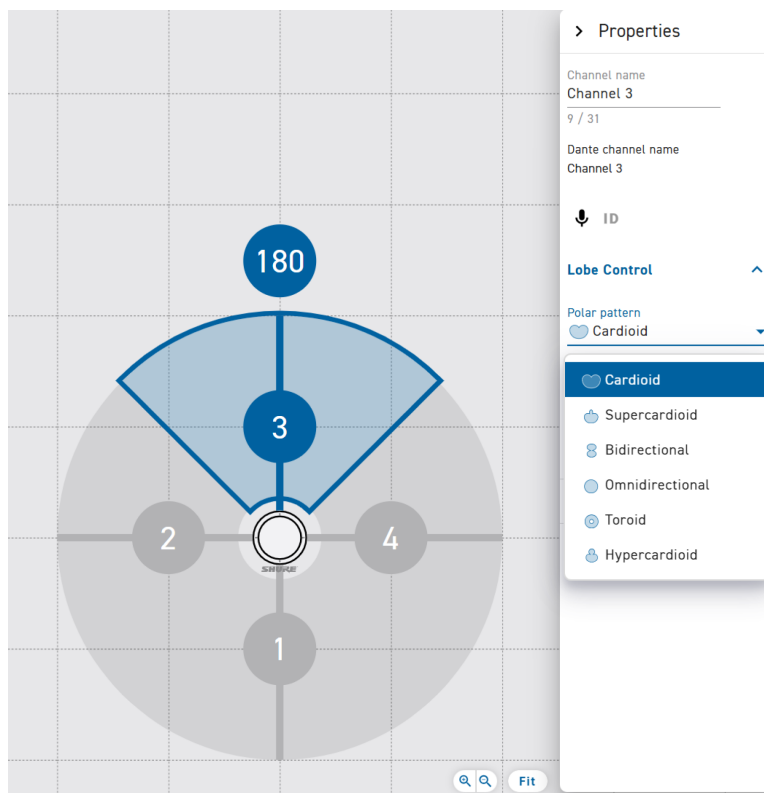

MXA320 polar patterns menu



For detailed polar pattern plots measured at different frequencies, see [MXA320 Polar Patterns](#).





Polar Pattern Options

Use this table to help plan coverage for MXA320 microphones. Select a polar pattern for each mic channel in the control software's Properties menu.

If you're using separate channels, the cardioid pattern is a good starting point. If you don't have many mic inputs on your DSP, the toroid pattern sends audio over 1 channel and provides coverage all around the mic while rejecting noise from directly above it.

MXA320 Polar Pattern Options

Polar Pattern	Directional Characteristic	Use When
 Cardioid	Wide on-axis pickup area. Least sensitive at 180° off axis	Talkers are likely to stay in the same general areas You need a flexible, all-purpose setting
	Slightly narrower front pickup area than cardioid. Least sensitive at 125° off axis	You need a more focused pattern than cardioid

Polar Pattern	Directional Characteristic	Use When
Supercardioid		
 Bidirectional	Captures sound on 2 opposite sides of the microphone in a figure-8 pattern	Two talkers are facing each other, sitting on opposite sides of a table You don't need independent gain control for each talker
 Omnidirectional	Picks up sound with equal sensitivity in all directions	Talkers are likely to move around The room has a quiet, controlled sound
 Toroid	Picks up sound from around the microphone and rejects sounds from directly above it	Talkers are likely to move around Noise from above is a concern (an HVAC vent or projector, for example)
 Hypercardioid	Narrower front pickup area than supercardioid. Least sensitive at 110° off axis	You need a more tightly focused pattern than supercardioid

For detailed polar pattern plots measured at different frequencies, see [MXA320 Polar Patterns](#).

How to Install the MXA320

Install MXA320 table array microphones on a flat, level surface where all meeting participants can easily reach the mic.

Installation Best Practices

- All talkers should be 2-3 feet (0.6-0.9 m) from the center of the microphone (4 feet maximum). See [Microphone Coverage](#) for more details.
- Don't place the microphone behind obstructions.
- Coverage depends on your room's acoustics, construction, and materials. Take these into consideration when planning.
- The MXA320 is designed for tables and should not be installed on walls or ceilings.

Installation Options

- [On table using included mounting tube kit](#)

- [A310-FM flush mount](#) (optional accessory)

Table Installation

Follow these steps to install the MXA320 on top of a table.

See the [A310-FM user guide](#) to install the microphone to be flush with a table.

To get started, you will need:

- MXA320 mounting tube kit
- Ethernet cable*
- Drill with 1-in. bit (2.5 cm)*

* Not included

1. Remove the 3 center screws on the bottom of the microphone.

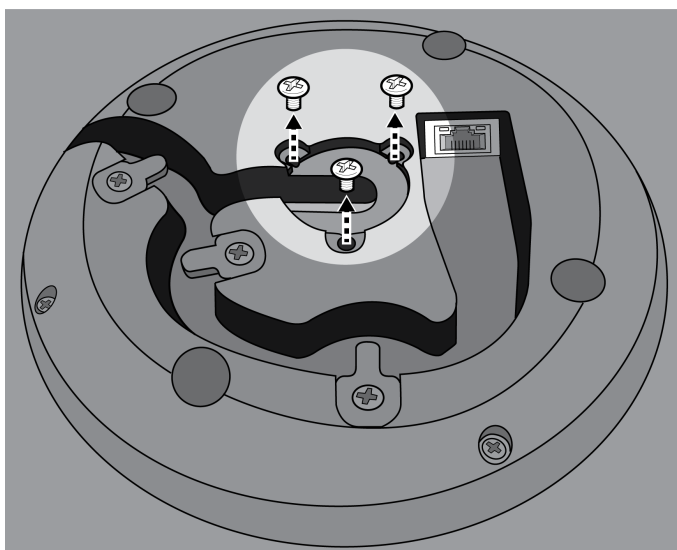

2. Plug the Ethernet cable into the microphone and guide it through the center exit path. When the cable is secured, guide it through the tube.

Note: If necessary, remove the retaining tabs to install thicker cable. Replace them after the cable is installed.

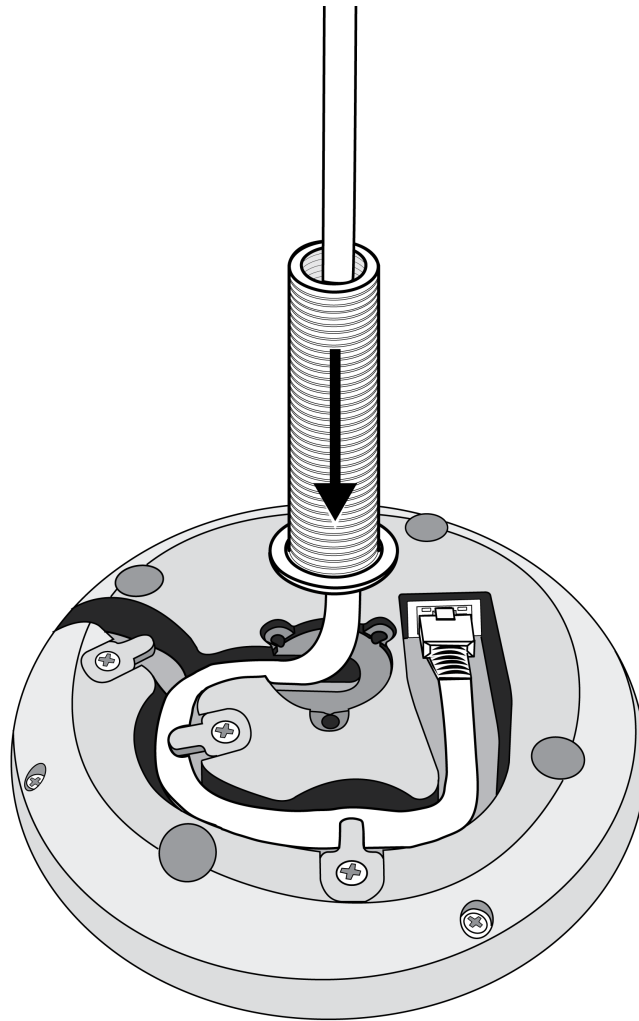

3. Align the tube in the center of the microphone. Install the 3 screws from step 1 to secure the tube.

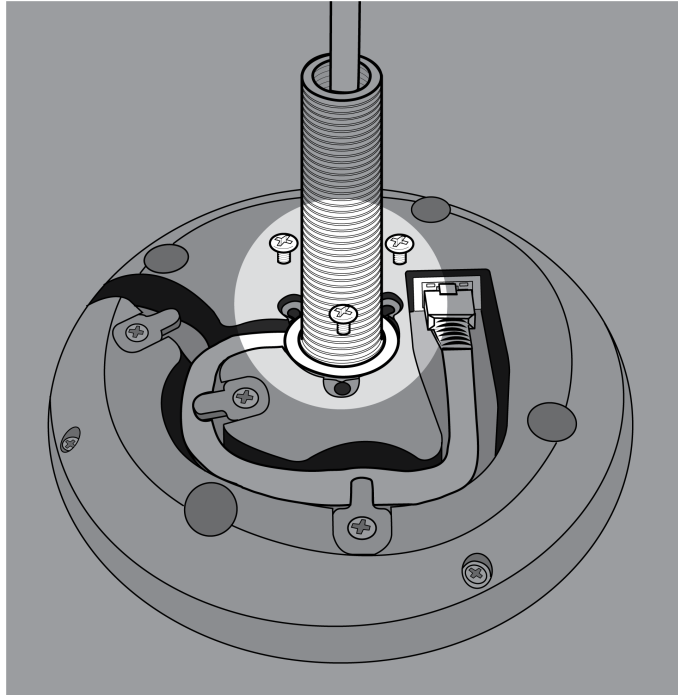

4. Slide one of the rubber washers onto the tube.

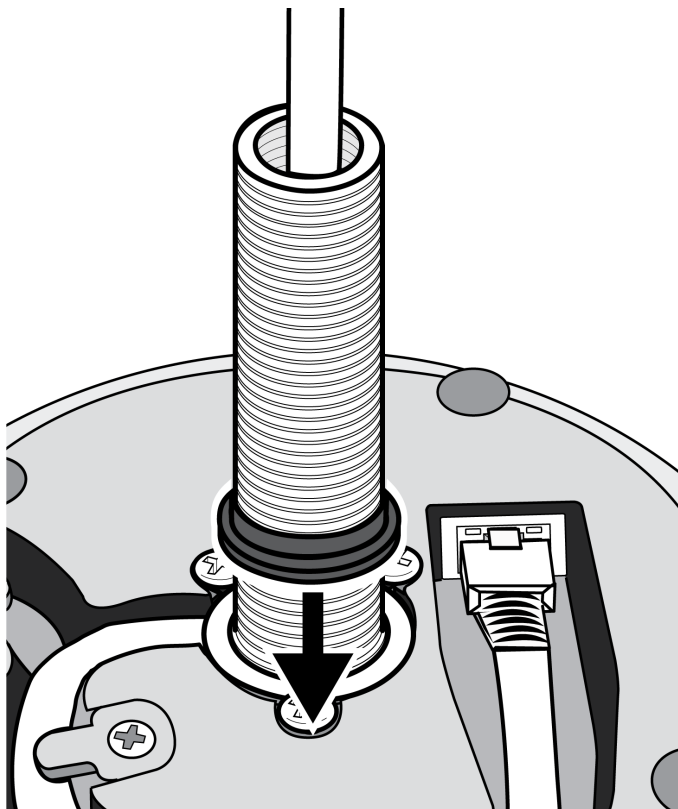

5. Drill a 1-inch hole (2.5 cm) through the table.

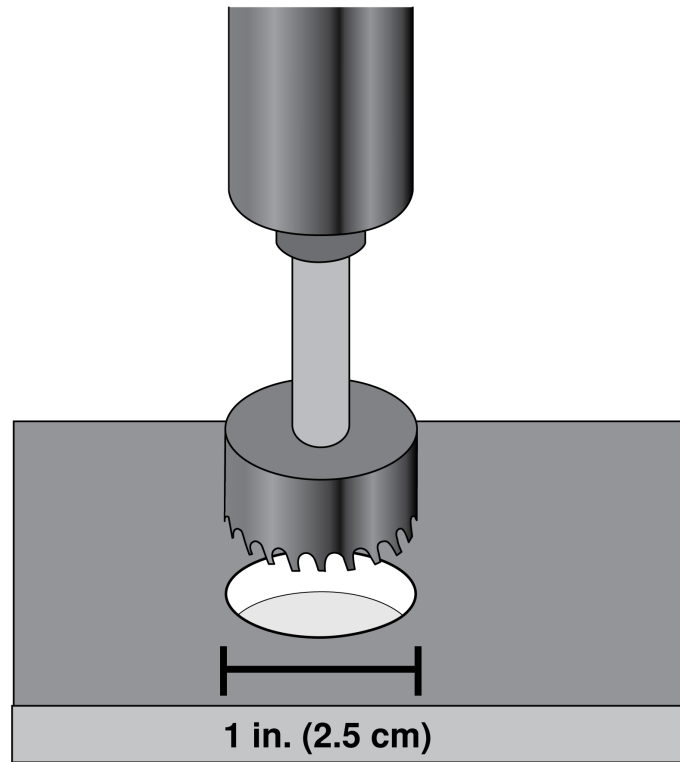

6. Guide the cable through the hole in the table. Then, place the tube through the hole in the table and gently press the microphone down.

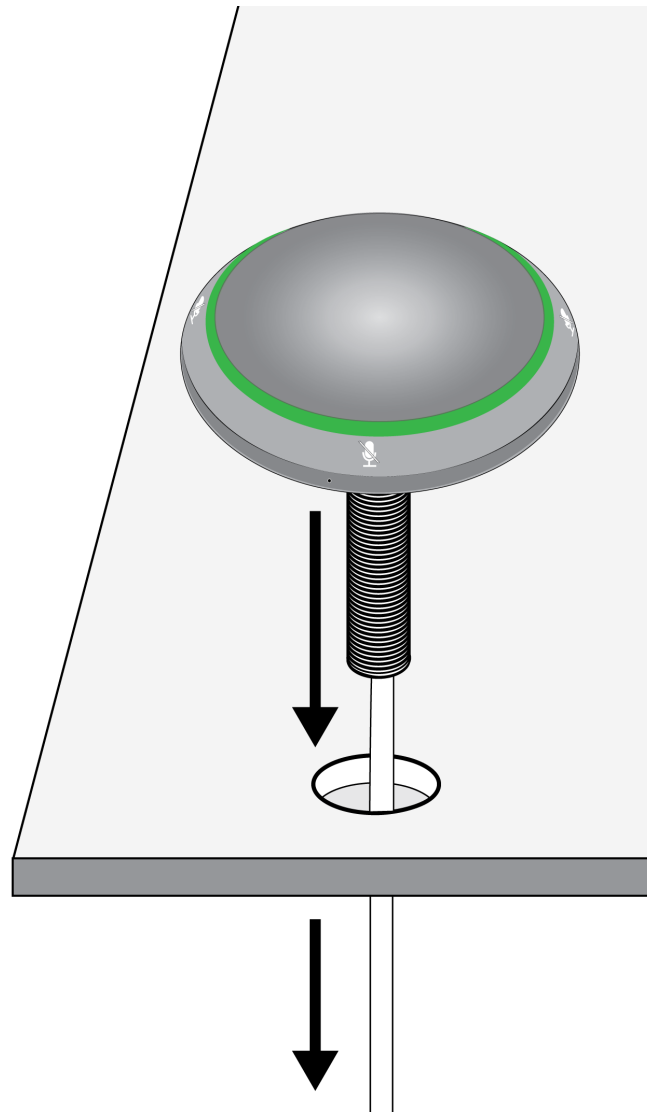

7. Attach the remaining rubber washer and wing nut from underneath the table. Tighten the wing nut to secure the microphone on the table.

Optional: Use the hole in the wing nut to insert a cable tie for cable management.

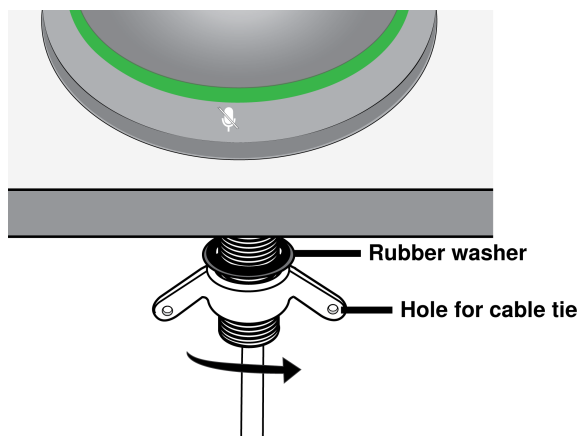

Install the Cable-Exit Plug

The plug covers the cable exit for permanent installations in which the cable is routed down through a table.

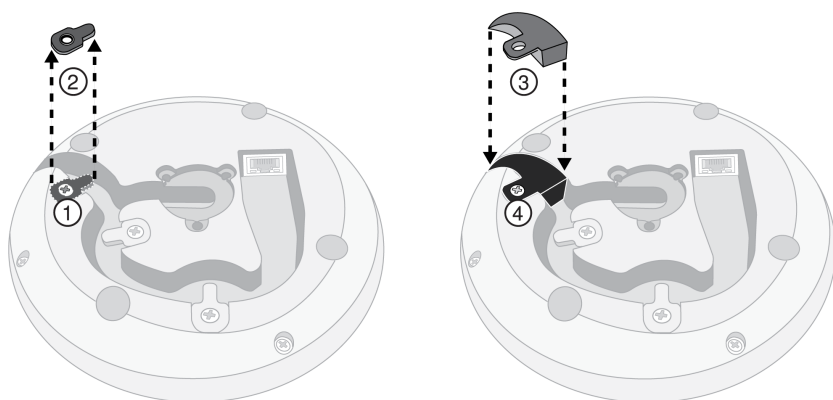

1. Remove the screw that holds the tab closest to the cable exit.
2. Remove the tab.
3. Insert the plug.
4. Replace the screw to secure the plug.

Use Designer's Auto Route

Designer's auto route speeds up the process of connecting systems with 1 audio processor and at least 1 microphone. Auto route also creates mute control routes in rooms with MXA network mute buttons. When you select Auto route, you can direct Designer to:

- Create audio routes and mute control routes
- Adjust audio settings
- Turn on mute synchronization
- Enable LED logic control for applicable devices

The settings are optimized for your particular combination of devices. You can adjust settings further, but auto route gives you a good starting point. Auto route works with any device in Designer.

To use auto route:

1. Place all relevant devices in a design.
2. Select Auto route. Designer optimizes microphone and DSP settings for your equipment combination.

If you remove or add devices, select Auto route again.

Note: The auto route process clears any manual routes you may have made in your design.

After auto routing a room, check and adjust settings to fit your needs. You may need to:

- Delete unnecessary routes.
- Check levels and adjust gain.
- Check that AEC reference signals are correctly routed and received in a test call.
- Fine-tune DSP blocks.
- Adjust your processor's matrix mixer routes.

If you want to auto route an online room, turn on online room editing in **File > Designer preferences**.

Note: Changes to an online room may cause audio to briefly drop out.

Refer to Designer's [Troubleshooting section](#) for help with routing.

Adjust Levels

Before adjusting levels, set up a way to listen to the microphone directly. You can make a test call with your videoconferencing software and have the other person tell you how the mic sounds. Two other common options are:

- [Use a Dante® headphone amp](#) or
- [Use Dante Virtual Soundcard](#)

To adjust levels, open the MXA320 in Designer or use the device web application. Each channel has 2 sets of gain faders:

Input gain (pre-gate): Channels view

- Affects a channel's gain before it reaches the automixer and affects the automixer's gating decision
- Boosting input gain makes the lobe more sensitive to sound sources and more likely to gate on when you use the automix output.
- Lowering input gain makes the lobe less sensitive and less likely to gate on.
- If you're only using direct outputs for each channel without the automixer, you only need to use these faders.

1	2	3	4	Automix
Channel 1 9 / 31	Channel 2 9 / 31	Channel 3 9 / 31	Channel 4 9 / 31	Automix Out 11 / 31

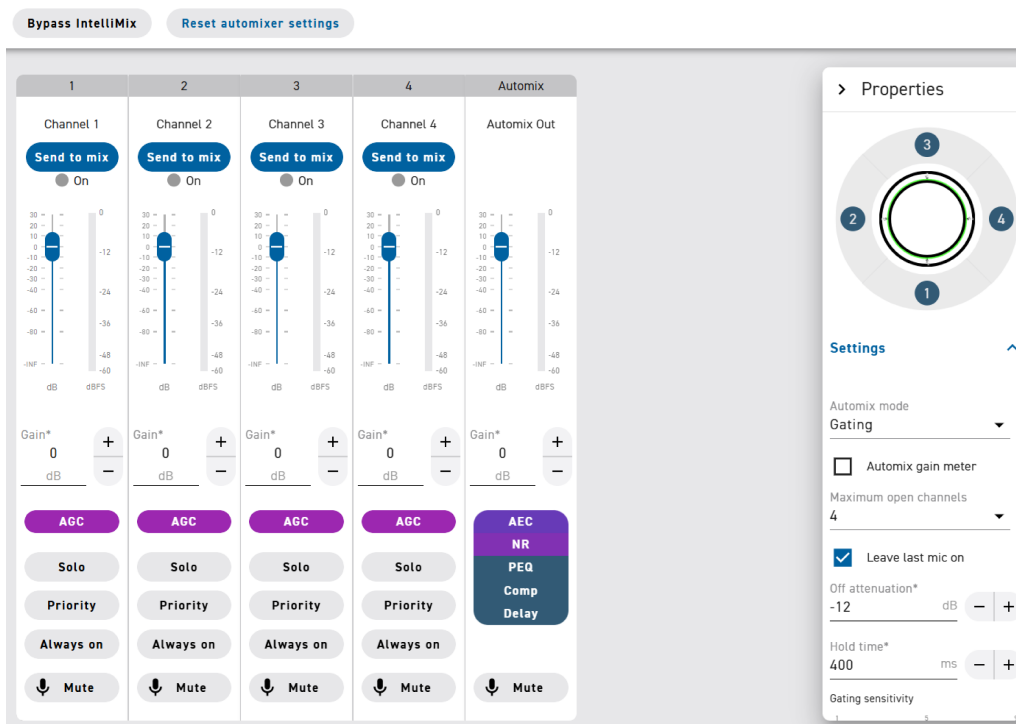

MXA320 IntelliMix view

You can adjust the automix output's overall gain using the automix output fader in the Channels or IntelliMix views.

Direct Out Tap Points

In the Channels view, use the Direct out tap point dropdown menu to choose what kind of direct output signal each channel should provide. All options include input gain, mute, and PEQ.

MXA320 Direct Tap Out Points

Setting	Function
Pre-processing/Pre-gate	Sends a signal without acoustic echo cancellation (AEC) or noise reduction to the channel output. Does not include automatic gain control (AGC) or automixer gating.
Post-processing/Pre-gate	Sends a signal with AEC and noise reduction to the channel output. Does not include AGC or automixer gating.

EQ Contour

The EQ contour is a low-cut filter that rolls off low frequencies to reduce unwanted noise from sources like table vibrations, HVAC systems, and other environmental noise.

To turn on, select the EQ contour button in Designer or the web application.

Parametric Equalizer

Maximize audio quality by adjusting the frequency response with the parametric equalizer.

Common equalizer applications:

- Improve speech intelligibility

- Reduce noise from HVAC systems or video projectors
- Reduce room irregularities
- Adjust frequency response for reinforcement systems

Setting Filter Parameters

Adjust filter settings by manipulating the icons in the frequency response graph, or by entering numeric values. Disable a filter using the checkbox next to the filter.

PEQ Filter Settings

Setting	Function
Filter Type	<p>Only the first and last band have selectable filter types.</p> <p>Parametric: Attenuates or boosts the signal within a customizable frequency range</p> <p>Low Cut: Rolls off the audio signal below the selected frequency</p> <p>Low Shelf: Attenuates or boosts the audio signal below the selected frequency</p> <p>High Cut: Rolls off the audio signal above the selected frequency</p> <p>High Shelf: Attenuates or boosts the audio signal above the selected frequency</p>
Frequency	Select the center frequency of the filter to cut or boost
Gain	Adjusts the level for a specific filter (+/- 18 dB)
Q	Adjusts the range of frequencies affected by the filter. As this value increases, the bandwidth becomes thinner.
Width	<p>Adjusts the range of frequencies affected by the filter. The value is represented in octaves.</p> <p>Note: The Q and width parameters affect the equalization curve in the same way. The only difference is the way the values are represented.</p>

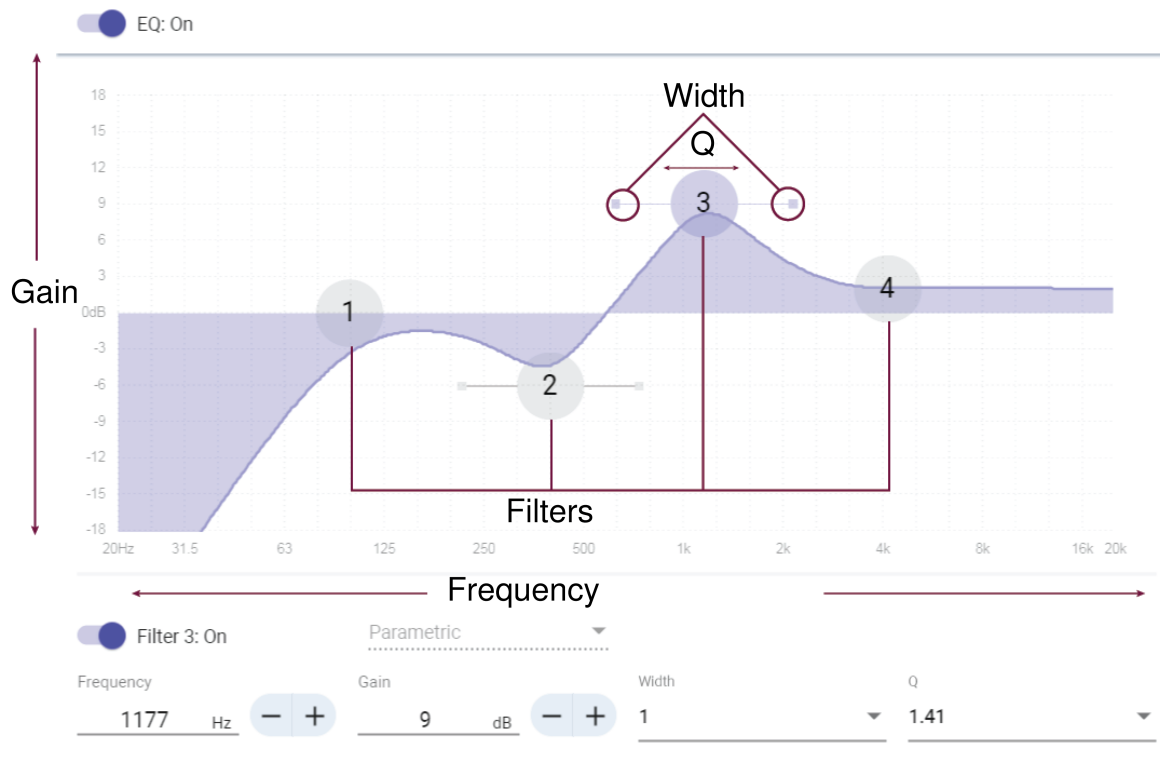

Copy and Paste Equalizer Channel Settings

Use to quickly apply the same PEQ setting across multiple channels.

1. Select the PEQ of the desired channel.
2. Click copy.
3. Select the channel to apply the PEQ setting to and click paste.

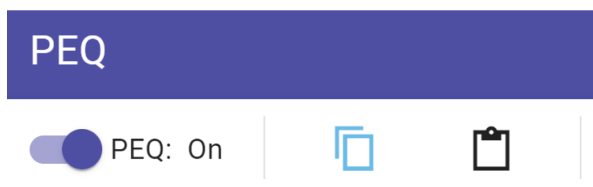

Equalizer Applications

Conferencing room acoustics vary based on room size, shape, and construction materials. Use the guidelines in following table.

Uses for EQ

EQ Application	Suggested Settings
Treble boost for improved speech intelligibility	Add a high shelf filter to boost frequencies greater than 1 kHz by 3-6 dB
HVAC noise reduction	Add a low cut filter to attenuate frequencies below 200 Hz

EQ Application	Suggested Settings
<p>Reduce flutter echoes and sibilance</p>	<p>Identify the specific frequency range that "excites" the room:</p> <ol style="list-style-type: none"> 1. Set a narrow Q value. 2. Increase the gain to between +10 and +15 dB, and then experiment with frequencies between 1 kHz and 6 kHz to pinpoint the range of flutter echoes or sibilance. 3. Reduce the gain at the identified frequency (start between -3 and -6 dB) to minimize the unwanted room sound.
<p>Reduce hollow, resonant room sound</p>	<p>Identify the specific frequency range that "excites" the room:</p> <ol style="list-style-type: none"> 1. Set a narrow Q value. 2. Increase the gain to between +10 and +15 dB, and then experiment with frequencies between 300 Hz and 900 Hz to pinpoint the resonant frequency. 3. Reduce the gain at the identified frequency (start between -3 and -6 dB) to minimize the unwanted room sound.

Mute Points in Control Software

The MXA320 has multiple mute points in Designer or the web application. Pressing one of the microphone's touch-sensitive mute buttons triggers a device mute.

There are 4 mute points in the control software:

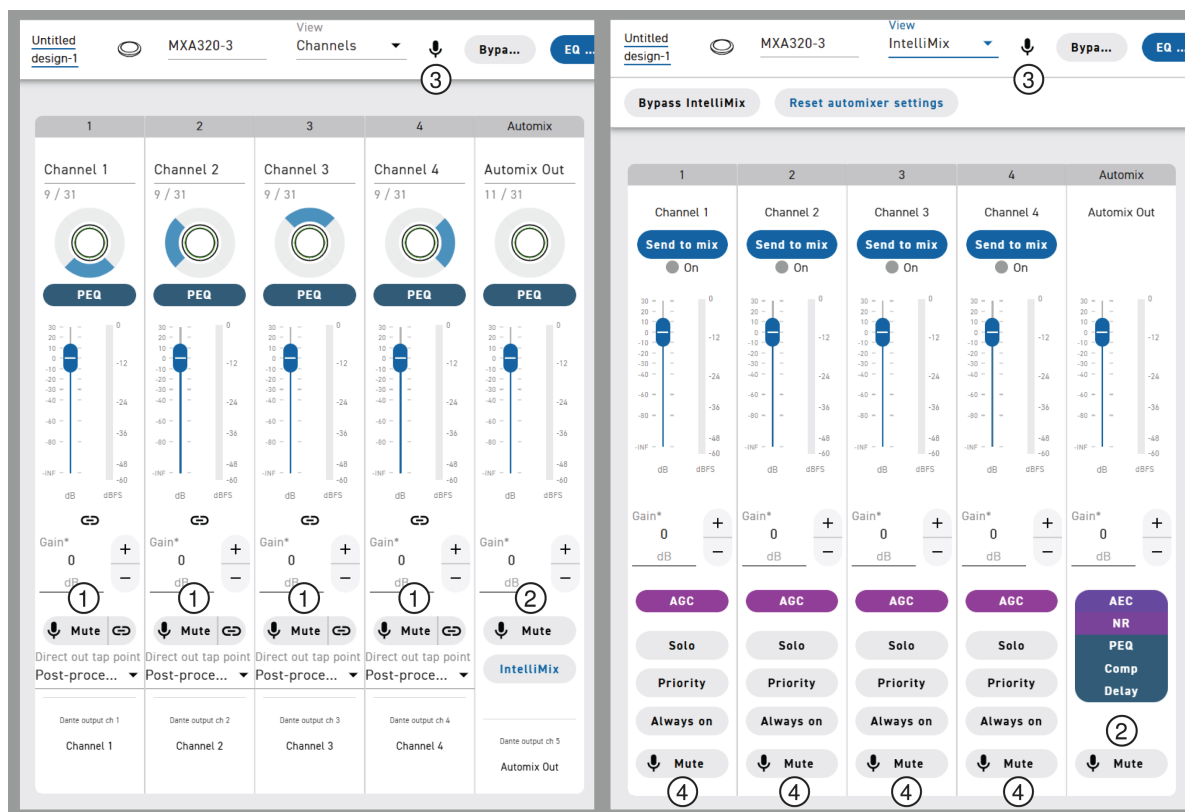

1. **Pre-gate channel mute:** Mutes the selected direct output channel
2. **Automix output mute:** Mutes the automix output channel
3. **Device mute:** Mutes the device (same as pressing a physical mute button). This mute button also changes the status LED.
4. **Post-gate channel mute:** Mutes the channel after the automixer gating has happened

See [Mute Buttons](#) for details about the available mute button settings.

Automix Channel

The automix output channel automatically mixes the audio from selected channels to deliver a convenient, single output. Route the automix channel to the desired destination using Designer or Dante Controller.

To send channels to the automix output, make sure that Send to mix is selected on the IntelliMix page.

Tip: If you're using a non-directional polar pattern (toroid or omnidirectional), you should remove directional channels unless they are specifically needed for your use case.

New Automix Behavior Compared to MXA310

The MXA320's automixer works slightly differently than the legacy MXA310 automixer.

On the MXA320, the main differences are:

- Non-directional channels (toroid or omnidirectional) are sent to the automix output and the corresponding direct output channel by default.
- You can use the Send to mix button on the IntelliMix page to control which channels are sent to the automix output.

The table describes the differences in more detail:

Comparison of MXA320 and MXA310 Automixers

MXA320	MXA310
<p>Scenario: 1 toroid channel and 3 cardioid channels</p> <p>Automixer behavior:</p> <p>Automix output: On Toroid channel is sent to automix output and corresponding direct output channel. 3 cardioid channels are sent to direct outputs. Adjust channels sent to automix output using Send to mix button.</p>	<p>Scenario: 1 toroid channel and 3 cardioid channels</p> <p>Automixer behavior:</p> <p>Automix output: Off Toroid channel is sent to direct output. 3 cardioid channels are sent to direct outputs. Can't send channels to automix output.</p>
<p>Scenario: 1 omnidirectional channel and 3 cardioid channels</p> <p>Automixer behavior:</p> <p>Automix output: On Omnidirectional channel is sent to automix output and corresponding direct output channel. 3 cardioid channels are sent to direct outputs. Adjust channels sent to automix output using Send to mix button.</p>	<p>Scenario: 1 omnidirectional channel and 3 cardioid channels</p> <p>Automixer behavior:</p> <p>Automix output: On Omnidirectional channel is sent to direct output. 3 cardioid channels are sent to automix output.</p>

Automix Settings

The settings on the IntelliMix page control automixer settings, post-gate gain and channel settings, and IntelliMix DSP settings.

To adjust automixer settings, go to [IntelliMix > Properties](#).

1. Bypass IntelliMix: Toggles all IntelliMix DSP settings on or off
2. Send to mix: When turned on, sends the channel to the automix output
3. Solo: Solos the selected channel
4. Priority: When selected, this channel gate activates regardless of the number of maximum open channels.
5. Always on: Keeps the channel open at all times
6. Bypass all EQ: Toggles all EQ settings on or off
7. Automix gain meter: When enabled, changes gain meters to display automix gating in real time. Channels that gate open will display more gain than channels that are closed (attenuated) in the mix.
8. Maximum open channels: Sets the maximum number of simultaneously active channels
9. Leave last mic on: Keeps the most recently used microphone channel active
10. Off attenuation: Sets the level of signal reduction in dB for when a channel is not active
11. Hold time: Sets how long a channel remains open after the level drops below the gate threshold
12. Gating sensitivity: Changes the threshold level at which the gate is opened and a channel becomes active
13. Speech gating threshold: Improves automixer gating and focuses on speech sources over noise sources

Automix Modes

Choose an automix mode that works for your particular installation. You should test the gating behavior in the space, adjusting the off attenuation, maximum number of open channels, input gain, and other settings to dial in a good sound for the room.

To select an automix mode, go to **IntelliMix > Properties > Settings**.

Available automix modes:

Gain Sharing

Gain sharing mode dynamically balances system gain between open and closed channels. The system gain remains consistent by distributing gain across channels to equal one open channel. The scaled gain structure helps to reduce noise when there is a high channel count. When fewer channels are used, the off attenuation setting is lower and provides transparent gating.

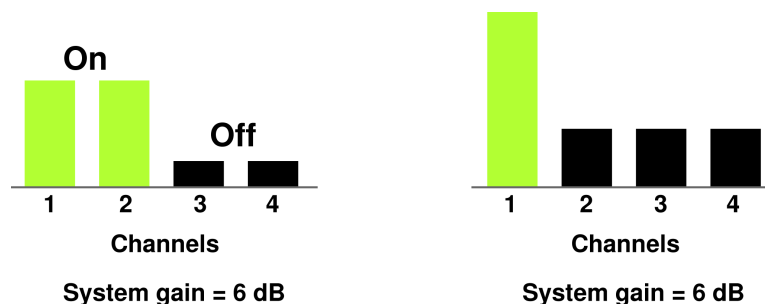

Both graphs show the same total system gain, regardless of the number of open or closed channels

Gating

Gating mode delivers fast-acting, seamless channel gating and consistent perceived ambient sound levels. The off attenuation value is applied to all inactive channels, regardless of the number of active channels.

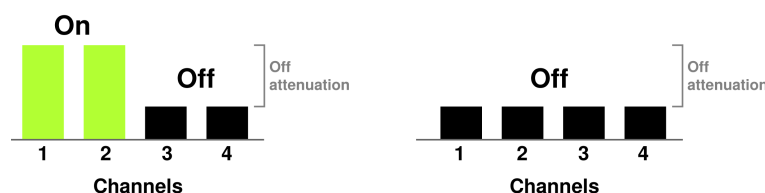

Example showing how off attenuation is applied to all inactive channels in gating mode

Manual

Manual mode sums all active channels and sends the summed signal over a single Dante output. This provides the option to route an individual signal for reinforcement or recording without using automixing. The level from each channel's input gain fader is used for the summed output.

Speech Gating Threshold

Speech gating threshold enhances the microphone's sound with:

- Improved automixer gating
- More focus on speech sources over noise sources

Examples of noise include:

- Shuffling papers across the table from a person talking
- Keyboard across the table from a person talking
- Loud food container across the table from a person talking

To use speech gating threshold, go to IntelliMix > Properties. Scroll down to turn on speech gating threshold.

Mute Sync

It's important to be able to see if a room is muted or unmuted during a call. You want devices to show the same mute status as the videoconferencing software. Shure devices use logic and mute sync to make this happen.

- **Logic:** Aligns mute status across Shure devices in the room. The processor (such as a P300, IntelliMix Room software, or an ANIUSB-MATRIX) is the controller.
- **Mute sync:** Aligns mute between the processor and the videoconferencing software, which is on a computer connected to the processor by USB. The processor's automix output is muted or unmuted to change the mute status of the system.

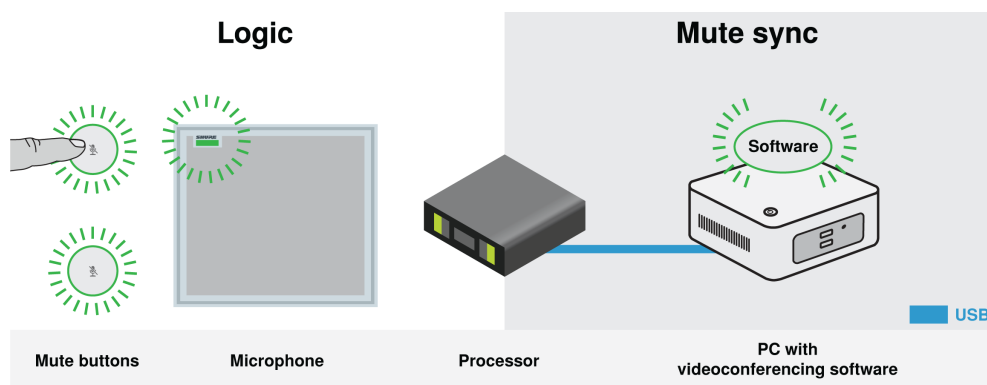

When mute sync is working correctly, you can mute a device ([networked mute button](#) or microphone mute button) or the videoconferencing software to mute the room.

To use mute sync:

1. In Designer, create audio and mute control routes between devices in the room.
2. Connect a computer with videoconferencing software to the processor's USB port.
3. Turn on mute sync and logic:
 - Processors: [Your device] > Settings > Mute control
 - MXA320, MXA310 ,and MXA mute button: Settings > Logic control > Mute control function > Logic out
 - Microphones without physical mute button: Logic is always on

Designer's auto route process configures all necessary mute sync and logic settings for you.

Compatible Shure Logic Devices

- P300 (Also mutes [supported soft codecs](#) connected by USB)
- ANIUSB-MATRIX (Also mutes [supported soft codecs](#) connected by USB)
- IntelliMix Room software (Also mutes [supported soft codecs](#) connected by USB)
- MXA901
- MXA902
- MXA910
- MXA920
- MXA710
- MXA320
- MXA310
- Network Mute Button
- ANI22-BLOCK

- ANI4IN-BLOCK
- Logic-enabled MX microphones connected to ANI22-BLOCK or ANI4IN-BLOCK
 - MX392
 - MX395-LED
 - MX396
 - MX405/410/415 used with MX400DP base
 - MX412D
 - MX418D

For help with specific mute sync implementations, [see our FAQs](#).

IntelliMix DSP

This device contains IntelliMix digital signal processing blocks that can be applied to the microphone's output. The DSP blocks include:

- Acoustic echo cancellation (AEC)
- Automatic gain control (AGC)
- Noise reduction
- Compressor
- Delay

To access, go to the IntelliMix view. Double-click a DSP block to open the settings.

DSP Best Practices

- Apply DSP blocks as needed. Run a test of your system without DSP and then add processing as needed to fix any issues that you hear in the audio signal.
- Use [Designer's auto route](#) as a DSP starting point. The auto route process applies Shure's recommended DSP settings for the room's mix of devices. You can then customize settings to fit your needs.
- Avoid duplicating DSP blocks.
 - Example: If you plan to use a mic's noise reduction processing, turn off the noise reduction on any connected processors (Shure or third-party). Conversely, if you use noise reduction on a connected processor, turn off the mic's noise reduction.
- Unless you encounter video that lags behind audio, set delay to off.

Acoustic Echo Cancellation (AEC)

Use acoustic echo cancellation (AEC) to keep your microphone signal clear and free of distracting echo on calls. Echo happens when your microphone picks up sound from your loudspeakers and sends it back to others on the call as echo.

AEC is a benefit for everyone else on the call: they hear you clearly with no annoying echo.

AEC Tips

When possible, optimize the acoustic environment using these tips:

- Reduce loudspeaker volume.
- Position loudspeakers farther from microphones.
- Avoid pointing loudspeakers directly at microphone coverage areas.

- Avoid duplicating AEC processing.
 - Example: If you plan to use a mic's AEC processing, turn off the AEC on any connected processors (Shure or third-party). Conversely, if you use AEC on a connected processor, turn off the mic's AEC.
 - Designer's [auto route process](#) selects Shure's recommended device for AEC processing based on the mix of Shure devices in the room.

Provide a Reference Signal for AEC

To apply AEC, provide a far end reference signal. For best results, use the same signal that feeds the room's local reinforcement system.

Designer's auto route process automatically routes an AEC reference signal. However, you should check that Designer chooses the reference signal you want to use.

To provide a reference signal, use Designer or Dante Controller to route the far end reference signal to the device's AEC Reference In channel.

Note: Always send an AEC reference signal to microphones with AEC processing, even if you are using a separate DSP for AEC. Some microphones use this reference signal to help improve mic coverage. Designer's auto route feature automatically creates these routes.

AEC Settings

Reference Meter	Use the reference meter to visually verify the reference signal is present. The reference signal should not be clipping.
ERLE	Echo return loss enhancement (ERLE) displays the amount of echo being removed in dB. If the reference source is connected properly, ERLE meter activity corresponds to the reference meter.
Reference	Indicates which channel is serving as the far end reference signal.
Non-Linear Processing	<p>The primary component of the acoustic echo canceller is an adaptive filter. Non-linear processing supplements the adaptive filter to remove any residual echo caused by acoustic irregularities or changes in the environment.</p> <p>Auto (default)*: For best results, use this setting. The non-linear processing level automatically adapts to changes in the acoustic environment.</p> <p>Low: Use in rooms with controlled acoustics and minimal echoes. This setting provides the most natural sound for full duplex.</p> <p>Medium: Use in typical rooms as a starting point. If you hear echo artifacts, try using the high setting.</p> <p>High: Use to provide the strongest echo reduction in rooms with bad acoustics, or in situations where the echo path frequently changes.</p>

* Auto setting available in firmware 6.2 and newer

Noise Reduction

Noise reduction keeps the focus on your voice by reducing the level of background noise. Noise reduction is best for constant noise sources such as:

- Loud HVAC systems
- Network switch or server fans
- Display projectors

Noise reduction is a dynamic processor which calculates the noise floor in a room and removes noise throughout the entire spectrum with maximum transparency.

Settings

Options: Low, medium, high, or auto*

The noise reduction setting reflects the amount of reduction in dB.

For best results, use the Auto setting so that the noise reduction level adapts to changes in the acoustic environment.

* Auto setting available in firmware 6.2 and newer

Automatic Gain Control (AGC)

Automatic gain control automatically adjusts channel levels to ensure consistent volume for all talkers in all scenarios. For quieter voices, it increases gain. For louder voices, it attenuates the signal.

Enable AGC on channels where the distance between the talker and the microphone may vary, or in rooms where many different people will use the conferencing system.

Automatic gain control happens post-gate (after the automixer) and does not affect when the automixer gates on or off.

Target Level (dBFS)

Use -37 dBFS as a starting point to ensure adequate headroom and adjust if necessary. This represents the RMS (average) level, which is different from setting the input fader according to peak levels to avoid clipping.

Maximum Boost (dB)

Sets the maximum amount of gain that can be applied

Maximum Cut (dB)

Sets the maximum attenuation that can be applied

Tip: Use the boost/cut meter (not available on all microphones) to monitor the amount of gain added or subtracted from the signal. If the meter is always reaching the maximum boost or cut level, adjust the input fader so the signal is closer to the target level.

Delay

Use delay to synchronize audio and video. When a video system introduces latency (where you hear someone speak, and their mouth moves later), add delay to align audio and video.

Delay is measured in milliseconds. If there is a significant difference between audio and video, start by using larger intervals of delay time (500-1000 ms). When the audio and video are slightly out of sync, use smaller intervals to fine-tune.

Compressor

Use the compressor to control the dynamic range of the selected signal.

Threshold

When the audio signal exceeds the threshold value, the level is attenuated to prevent unwanted spikes in the output signal. The amount of attenuation is determined by the ratio value. Perform a soundcheck and set the threshold 3-6 dB above average talker levels, so the compressor only attenuates unexpected loud sounds.

Ratio

The ratio controls how much the signal is attenuated when it exceeds the threshold value. Higher ratios provide stronger attenuation. A lower ratio of 2:1 means that for every 2 dB the signal exceeds the threshold, the output signal will only exceed the threshold by 1 dB. A higher ratio of 10:1 means a loud sound that exceeds the threshold by 10 dB will only exceed the threshold by 1 dB, effectively reducing the signal by 9 dB.

Use Presets

Use presets to save device settings so that you can quickly recall them later. Presets capture all current device settings but do not save routing information.

To save or apply presets, go to the device's Presets view in Designer or the web application. There are 10 preset slots available on the device.

Designer has room presets and device presets. Learn more in the [Designer user guide](#).

Save a Preset

1. Go to Presets.
2. Select an open preset slot.
3. Enter a name for the preset and save.

Apply a Preset

1. Go to Presets.
2. Choose the preset you want to apply.
3. Select Apply. The applied preset has a check mark next to it.

Note: Any changes made after applying a preset are not saved to that preset. Save new settings to a new preset slot or overwrite the old preset.

Security

Encryption

Audio is encrypted with the Advanced Encryption Standard (AES-256), as specified by the US Government National Institute of Standards and Technology (NIST) publication FIPS-197. Shure devices that support encryption require a password to make a connection. Encryption is not supported with third-party devices.

In Designer, you can turn on encryption for all devices in a room: [Your room] > Settings > Audio encryption.

To activate encryption in the web application, go to Settings > Audio encryption > Enable encryption.

Important: For encryption to work:

- All Shure devices on your network must use encryption.
- Disable AES67 in Dante Controller. AES67 and AES-256 cannot be used at the same time.

Set Up the 802.1X Protocol for a Device

Select Shure devices support the IEEE 802.1X port access protocol for network authentication.

Important: To use the 802.1X security protocol with Shure devices, set the network switch to multiple host authentication. You must also make accommodations to allow the audio NIC to connect to the network. The audio NIC doesn't support the 802.1X protocol.

To set up 802.1X, you will need:

- Details about your authentication server's EAP method
- Any required credentials or certificates for that method, for example:
 - MD5 and PWD
 1. User ID and passphrase
 - TLS and PEAP
 1. User ID and passphrase
 2. Certificate (with certificate types) in the .PEM format
- Any passwords to access the devices if they are password locked

Setting up 802.1X is a two-part process.

Step 1: Configure Settings on Test Network

1. Connect the device to a test network that *does not* have 802.1X enabled, and discover it using Designer.
2. Set a device password if desired.
3. Double-click the device and go to **Settings > Network > 802.1X**.
4. Choose your EAP method from the menu.
5. Enter any required credentials and load any necessary certificates.
6. Press Save to save the 802.1X settings to the device.
7. Enable 802.1X and select Reboot now.

Step 2: Connect to a Credentialed Network

1. Connect your device to the credentialed network.
2. Ensure that Designer is connected to the credentialed network.
3. Verify that the device appears in Designer. If it doesn't, reconnect to the test network and check all 802.1X settings for the selected EAP method.

Turn Off or Clear 802.1X Settings

You can turn off 802.1X settings temporarily, or clear them from the device. Open the device and go to **Settings > Network > 802.1X**

- **Disable:** Click the 802.1X switch to turn off 802.1X settings. Click the switch again to enable 802.1X.
- **Clear:** Click Clear 802.1X settings to remove 802.1X settings from the device.

Note: Resetting to factory default clears all 802.1X settings.

Change 802.1X Settings

You may need to change a device's 802.1X settings if the enterprise's 802.1X settings are changing. The best way to do this is to change the 802.1X settings on the devices, and then make changes to the authentication server.

To change device settings:

1. While still connected to the credentialed network, find the device in Designer and go to **Settings > Network > 802.1X**.
2. Make changes and click Save.
3. Make any changes to the authentication server.
4. Reboot your devices. The devices should connect to the credentialed network with the updated 802.1X settings.

Troubleshooting 802.1X Setup Issues

If the device doesn't appear in Designer on the credentialed network, there's a problem with the device's 802.1X settings. To troubleshoot, take the device off the credentialed network and connect it to the test network. You can make any necessary changes to the 802.1X settings, and then reconnect to the credentialed network.

If you attempt to enable 802.1X on a device, but the authentication fails, you will see this notification:

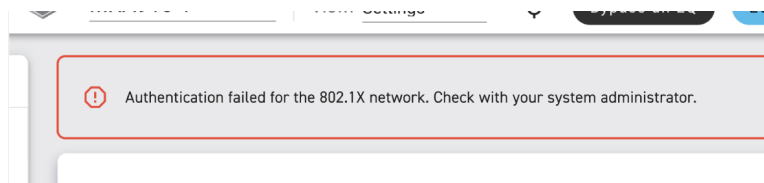

If this occurs, check with your system administrator.

Networking

Networking Best Practices

When connecting Shure devices to a network, use the following best practices:

- Always use a "star" network topology by connecting each device directly to the switch or router.
- For most uses, connect Shure networked devices to the same network and set to the same subnet.
 - If needed, use Designer to [discover devices across subnets](#).
- Allow all Shure software through the firewall on your computer.
- Use only 1 DHCP server per network. Disable DHCP addressing on additional servers.
- Power on the switch and DHCP server before powering on the Shure devices.
- To expand the network, use multiple switches in a star topology.
- Keep device firmware updated to avoid compatibility issues.

Switch and Cable Recommendations for Dante Networking

Switches and cables determine how well your audio network performs. Use high-quality switches and cables to make your audio network more reliable.

Network switches should have:

- Gigabit ports. 10/100 switches may work on small networks, but gigabit switches perform better.
- Power over Ethernet (PoE) or PoE+ ports for any devices that require power
- Management features to provide information about port speed, error counters, and bandwidth used
- Ability to switch off Energy Efficient Ethernet (EEE). EEE (also known as "Green Ethernet") may cause audio dropouts and problems with clock synchronization.
- Diffserv (DSCP) Quality of Service (QoS) with strict priority and 4 queues

Ethernet cables should be:

- Cat5e or better
- Shielded

For more information, [see our FAQ](#) about switches to avoid.

Device IP Configuration

This Shure device uses 2 IP addresses: one for Shure control, and one for Dante audio and control. For most installations, the Shure control and Dante audio IP addresses should be in the same subnet range.

- **Shure control**
 - Carries data for Shure control software, firmware updates, and third-party control systems (such as AMX or Crestron)
- **Dante audio and control**
 - Carries Dante digital audio and control data for Dante Controller
 - Requires a wired, gigabit Ethernet connection to operate

To access these settings in Designer, go to [Your device] > Settings > IP configuration.

Devices with 1 RJ-45 port do not natively support Dante split or redundant modes.

Note: [Refer to our FAQ](#) if you're using any Shure profiles on NETGEAR M4250-series switches.

Setting Latency

Latency is the amount of time for a signal to travel across the system to the outputs of a device. To account for variances in latency time between devices and channels, Dante has a predetermined selection of latency settings. When the same setting is selected, it ensures that all Dante devices on the network are in sync.

These latency values should be used as a starting point. To determine the exact latency to use for your setup, deploy the set-up, send Dante audio between your devices, and measure the actual latency in your system using Audinate's Dante Controller software. Then round up to the nearest latency setting available, and use that one.

Use Audinate's Dante Controller software to change latency settings.

Latency Recommendations

Latency Setting	Maximum Number of Switches
0.25 ms	3
0.5 ms (default)	5
1 ms	10
2 ms	10+

QoS (Quality of Service) Settings

QoS settings assign priorities to specific data packets on the network, ensuring reliable audio delivery on larger networks with heavy traffic. This feature is available on most managed network switches. Although not required, assigning QoS settings is recommended.

Note: Coordinate changes with the network administrator to avoid disrupting service.

To assign QoS values, open the switch interface and use the following table to assign Dante[®]-associated queue values.

- Assign the highest possible value (shown as 4 in this example) for time-critical PTP events
- Use descending priority values for each remaining packet.

Dante QoS Priority Values

Priority	Usage	DSCP Label	Hex	Decimal	Binary
High (4)	Time-critical PTP events	CS7	0x38	56	111000
Medium (3)	Audio, PTP	EF	0x2E	46	101110
Low (2)	(reserved)	CS1	0x08	8	001000
None (1)	Other traffic	BestEffort	0x00	0	000000

Note: Switch management may vary by manufacturer and switch type. Consult the manufacturer's product guide for specific configuration details.

For more information on Dante requirements and networking, visit www.audinate.com.

Networking Terminology

PTP (Precision Time Protocol): Used to synchronize clocks on the network

DSCP (Differentiated Services Code Point): Standardized identification method for data used in layer 3 QoS prioritization

Ports, Protocols, and Firewall Rules

For information about IP ports and protocols or firewall rules, go to:

- [IP Ports and Protocols for Shure Devices](#)
- [Firewall Rules for Shure Software Applications](#)

Digital Audio Networking

Dante digital audio is carried over standard Ethernet and operates using standard internet protocols. Dante provides low latency, tight clock synchronization, and high Quality-of-Service (QoS) to provide reliable audio transport to a variety of Dante devices. Dante audio can coexist safely on the same network as IT and control data, or can be configured to use a dedicated network.

Compatibility with Dante Domain Manager

This device is compatible with Dante Domain Manager software (DDM). DDM is network management software with user authentication, role-based security, and auditing features for Dante networks and Dante-enabled products.

Considerations for Shure devices controlled by DDM:

- When you add Shure devices to a Dante domain, set the local controller access to Read Write. Otherwise, you won't be able to access Dante settings, perform a factory reset, or update device firmware.
- If the device and DDM can't communicate over the network for any reason, you won't be able to control Dante settings, perform a factory reset, or update device firmware. When the connection is reestablished, the device follows the policy set for it in the Dante domain.
- If Dante device lock is on, DDM is offline, or the configuration of the device is set to Prevent, some device settings are disabled. These include: Dante encryption, MXW association, AD4 Dante browse and Dante cue, and SCM820 linking.

Refer to [Dante Domain Manager's documentation](#) for more information.

Dante Flows for Shure Devices

Dante flows get created any time you route audio from one Dante device to another. One unicast Dante flow can contain up to 4 audio channels. For example: sending all 5 available channels from an MXA310 to another device uses 2 Dante flows, because 1 flow can contain up to 4 channels.

Every Dante device has a specific number of transmit flows and receive flows. The number of flows is determined by Dante platform capabilities.

Dante Flows for Shure Devices

Dante Platform	Shure Devices Using Platform	Transmit Flow Limit	Receive Flow Limit
Brooklyn II	ULX-D, SCM820, MXWAPT, MXWANI, P300, MXCWAPT	32	32
Brooklyn II (without SRAM)	MXA920, MXA910, MXA902, MXA710, AD4, AD600, APXD2	16	16
IP Core	MXA920-V3, MXA902-V3, MXA901, DCA901	32	32
Ultimo/UltimoX	MXA310, ANI4IN, ANI4OUT, ANIUSB-MATRIX, ANI22, MXN5-C	2	2
DEP	ANIUSB-MATRIX-V3, MXN-AMP, MXN5-C-V3, MXN-6, MXA320	2	2
DAL	IntelliMix Room	16	16

[Learn more about Dante flows in our FAQs](#) or from [Audinate](#).

AES67

AES67 is a networked audio standard that enables communication between hardware components which use different IP audio technologies. This Shure device supports AES67 for increased compatibility within networked systems for live sound, integrated installations, and broadcast applications.

The following information is critical when transmitting or receiving AES67 signals:

- Update Dante Controller software to the newest available version to ensure the AES67 configuration tab appears.
- Before turning encryption on or off, you must disable AES67 in Dante Controller.
- AES67 cannot operate when the transmit and receive devices both support Dante.

Shure Device Supports:	Device 2 Supports:	AES67 Compatibility
Dante and AES67	Dante and AES67	No. Must use Dante.
Dante and AES67	AES67 without Dante. Any other audio networking protocol is acceptable.	Yes

Separate Dante and AES67 flows can operate simultaneously. The total number of flows is determined by the maximum flow limit of the device.

Sending Audio from a Shure Device

All AES67 configuration is managed in Dante Controller software. For more information, refer to the Dante Controller user guide.

1. Open the Shure transmitting device in Dante Controller.
2. Enable AES67.

3. Reboot the Shure device.
4. Create AES67 flows according to the instructions in the [Dante Controller user guide](#).

Receiving Audio from a Device Using a Different Audio Network Protocol

Third-party devices: When the hardware supports SAP, flows are identified in the routing software that the device uses. Otherwise, to receive an AES67 flow, the AES67 session ID and IP address are required.

Shure devices: The transmitting device must support SAP. In Dante Controller, a transmit device (appears as an IP address) can be routed like any other Dante device.

Use Command Strings

This device receives logic commands over the network. Many parameters controlled through Designer can be controlled using a third-party control system, using the appropriate command string.

Common applications:

- Mute
- LED color and behavior
- Loading presets
- Adjusting levels

A complete list of command strings is available at:

shure.com/en-US/docs/commandstrings/mxa320

Troubleshooting

MXA320 Troubleshooting

Problem	Solution
Microphone sound quality is muffled or hollow	<p>Check that channels are aimed at the desired area and that mic output levels are sufficient.</p> <p>Make sure channels are not accidentally muted.</p>
MXA320 does not show up in Designer/Shure Update Utility	<p>Ensure that the device has power.</p> <p>Check that Designer and Shure Update Utility are updated to the latest version.</p> <p>Make sure MXA320 is on the same network as the computer with Designer/Shure Update Utility.</p> <p>Turn off network interfaces not used to connect to the device (such as Wi-Fi).</p> <p>Check that DHCP server is functioning (if applicable).</p> <p>Reset the device if necessary.</p> <p>Refer to the no online devices FAQ for more help.</p> <p>Contact Shure if these steps do not resolve your issue.</p>

Problem	Solution
Audio is not present or is quiet/distorted	<p>Check cables.</p> <p>Make sure channels are not accidentally muted.</p> <p>Check where audio metering stops. Then check that all Dante and matrix mixer routes have been created correctly.</p> <p>Check that channels are aimed at the desired area and that mic output levels are sufficient.</p> <p>If using automixing, check the settings to ensure channels are gating on and off properly.</p>
No lights	<p>Go to Settings > Lights in the control software. Check if any light settings are turned off.</p> <p>If the device is in a room using Designer's call status feature, mute status LEDs are off when not in a call.</p>
Automixer is missing a channel	<p>Check that all relevant channels have the Send to mix option selected in the IntelliMix view.</p> <p>Check that all relevant faders are set correctly.</p>
Microphone does not power on	<p>Check that MXA320 is plugged in to a PoE source.</p> <p>Test any network cables and connections.</p>
Can't get multiple MXA320s to mute/unmute at the same time	<p>To mute/unmute all MXA320s in a room simultaneously, set up mute sync between the mics and the DSP (such as a P300 or IntelliMix Room software).</p> <ol style="list-style-type: none"> 1. In Designer, create audio routes between the devices. 2. Connect a computer with supported videoconferencing software to the DSP's USB port. 3. Turn on mute sync and logic on the DSP and all MXA320s: DSP: Settings > Mute control MXA320: Settings > Logic control > Mute control function > Logic out <p>See Mute Buttons for more detail.</p>

Additional Resources

- [Shure Knowledge Base FAQs](#)
- [Command strings for Shure devices](#)
- [IP Ports and Protocols for Shure Devices](#)
- [Firewall Rules for Shure Software Applications](#)

- [Shure API documentation](#)
- [Shure Enterprise Networking Troubleshooting Checklist](#)
- [Training from the Shure Audio Institute](#)
- [Shure Systems YouTube channel](#)

Download Shure Software

- [Shure Designer](#)
- [ShureCloud](#)
- [Shure Update Utility](#)
- [Shure Discovery](#)
- [Software and firmware archive](#)

MXA320 Specifications

All specifications measured from cardioid polar pattern. Values for all patterns are within ± 3 dB of these specifications unless otherwise noted.

General

Polar Pattern

All channels independently adjustable

Cardioid, hypercardioid, supercardioid, toroid, omnidirectional, bidirectional

Connector Type

RJ45

Cable Requirements

Cat 5e or higher (shielded cable recommended)

Power Requirements

Power over Ethernet (PoE), Class 0

Power Consumption

5 W maximum

Control Software

Shure Designer or web application

Operating Temperature Range

-6.7°C (20°F) to 40°C (104°F)

Storage Temperature Range

-29°C (-20°F) to 74°C (165°F)

Audio

Microphone Elements

4 EMC

Frequency Response

100 Hz to 20 kHz

AES67 or Dante Digital Output

Channel Count	6 total channels: 4 direct outputs, 1 automix output, and 1 AEC reference input
Sampling Rate	48 kHz
Bit Depth	24

Sensitivity

at 1 kHz, -15 dB gain setting

-21 dBFS/Pa

Maximum SPL

1 kHz at 1% THD, -15 dB gain setting

115.2 dB SPL

Signal-To-Noise Ratio

Ref. 94 dB SPL at 1 kHz, -15 dB gain setting

Cardioid	75 dB
Toroid	67 dB

Latency

Not including Dante latency

< 1.7 ms

Self Noise

-15 dB gain setting

Cardioid	19.2 dB SPL-A
Toroid	26.8 dB SPL-A

Dynamic Range

-15 dB gain setting

Cardioid	96 dB
Toroid	90 dB

Built-in Digital Signal Processing

Equalizer (4-band parametric), acoustic echo cancellation (AEC), automatic gain control (AGC), noise reduction, compressor, delay, mute, gain

Acoustic Echo Cancellation Tail Length

Up to 250 ms

MXA320 Frequency Response

Frequency response measured directly on-axis from a distance of 2 feet (0.6 m).

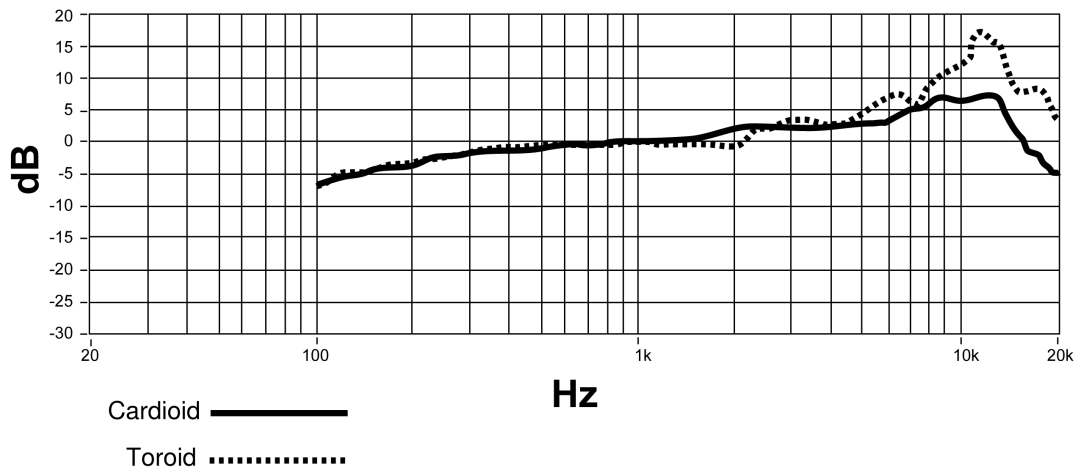

Polar Patterns

MXA320 polar response measured directly on-axis from a distance of 2 feet (0.6 m).

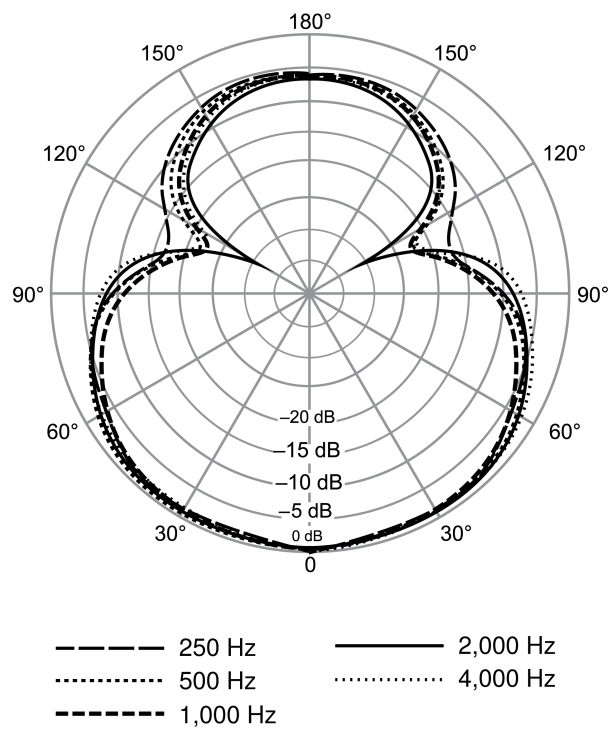

Hypercardioid

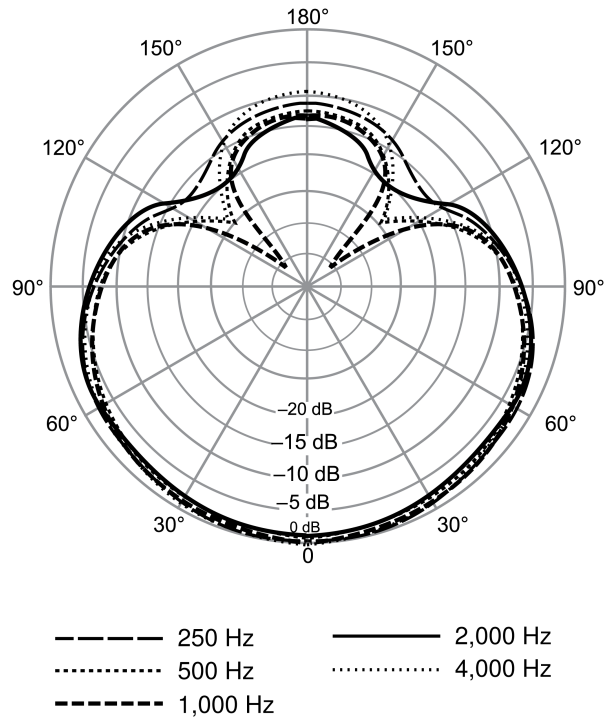

Supercardioid

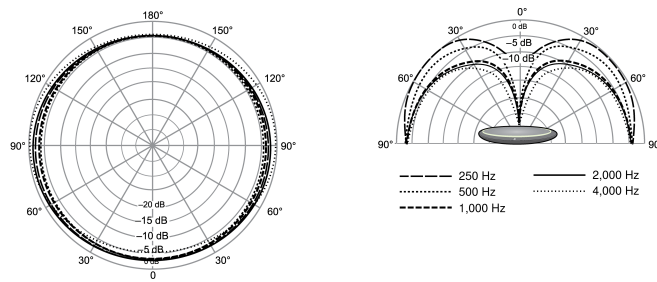

Toroid

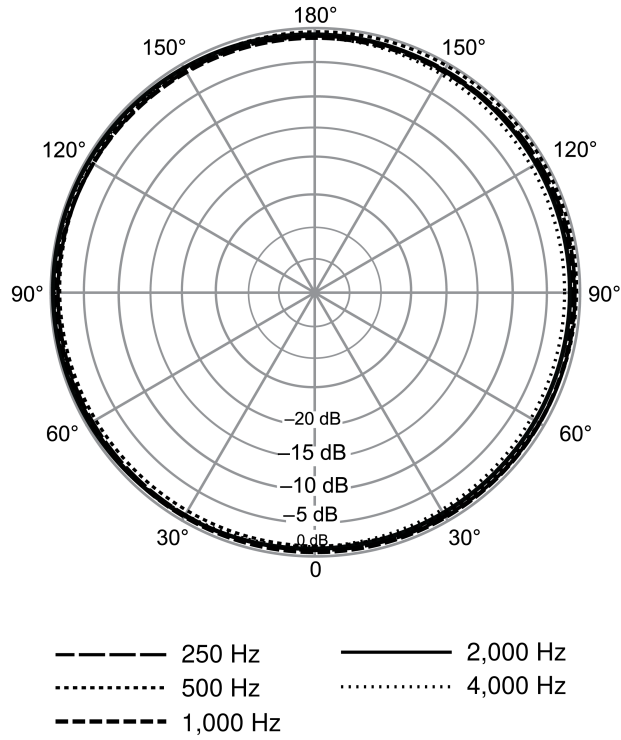

Omnidirectional

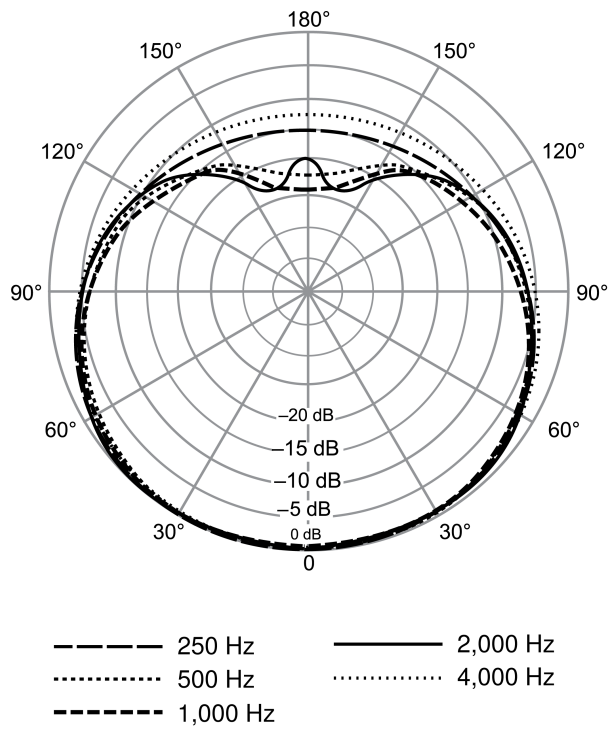

Cardioid

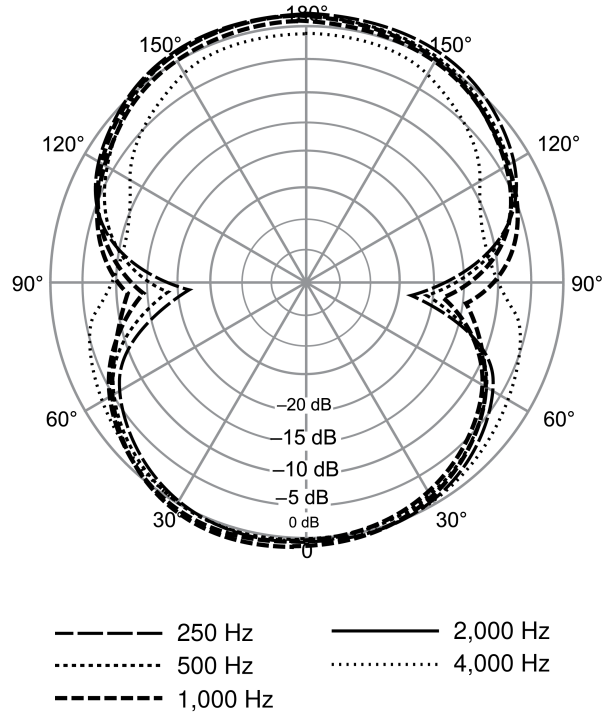

Bidirectional

MXA320 Dimensions

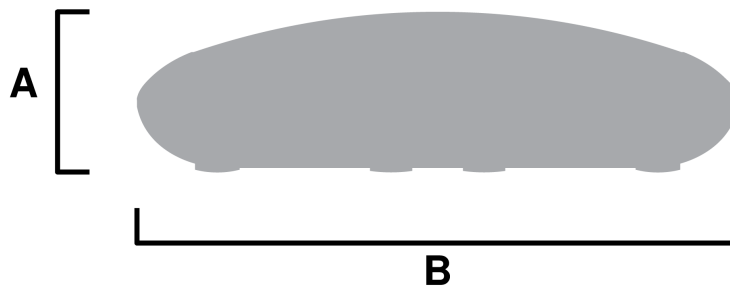

- A: 1.43 in. (36.3 mm)
- B: 5.28 in. (134 mm)

Weight

0.83 lb. (375 g)

Explanation of Symbols



This symbol indicates that dangerous voltage constituting a risk of electric shock is present within this unit.



This symbol indicates that there are important operating and maintenance instructions in the literature accompanying this unit.

Important Safety Instructions

1. READ these instructions.
2. KEEP these instructions.
3. HEED all warnings.
4. FOLLOW all instructions.
5. DO NOT use this apparatus near water.
6. CLEAN ONLY with dry cloth.
7. DO NOT block any ventilation openings. Allow sufficient distances for adequate ventilation and install in accordance with the manufacturer's instructions.
8. DO NOT install near any heat sources such as open flames, radiators, heat registers, stoves, or other apparatus (including amplifiers) that produce heat. Do not place any open flame sources on the product.
9. DO NOT defeat the safety purpose of the polarized or grounding type plug. A polarized plug has two blades with one wider than the other. A grounding type plug has two blades and a third grounding prong. The wider blade or the third prong are provided for your safety. If the provided plug does not fit into your outlet, consult an electrician for replacement of the obsolete outlet.
10. PROTECT the power cord from being walked on or pinched, particularly at plugs, convenience receptacles, and the point where they exit from the apparatus.
11. ONLY USE attachments/accessories specified by the manufacturer.
12. USE only with a cart, stand, tripod, bracket, or table specified by the manufacturer, or sold with the apparatus. When a cart is used, use caution when moving the cart/apparatus combination to avoid injury from tip-over.



13. UNPLUG this apparatus during lightning storms or when unused for long periods of time.
14. REFER all servicing to qualified service personnel. Servicing is required when the apparatus has been damaged in any way, such as power supply cord or plug is damaged, liquid has been spilled or objects have fallen into the apparatus, the apparatus has been exposed to rain or moisture, does not operate normally, or has been dropped.
15. DO NOT expose the apparatus to dripping and splashing. DO NOT put objects filled with liquids, such as vases, on the apparatus.
16. The MAINS plug or an appliance coupler shall remain readily operable.
17. The airborne noise of the Apparatus does not exceed 70dB (A).
18. Apparatus with CLASS I construction shall be connected to a MAINS socket outlet with a protective earthing connection.
19. To reduce the risk of fire or electric shock, do not expose this apparatus to rain or moisture.
20. Do not attempt to modify this product. Doing so could result in personal injury and/or product failure.
21. Operate this product within its specified operating temperature range.
22. Follow local regulations and consult qualified personnel if the product installation or relocation requires construction work. Choose mounting hardware and an installation location that can support the weight of the product. Avoid locations subject to constant vibration. Use the required tools to install the product properly. Inspect the product periodically.
23. If your product has a feature to log in, upon first time start up, you must change your password.

WARNING:

- Voltages in this equipment are hazardous to life. No user-serviceable parts inside. Refer all servicing to qualified service personnel. The safety certifications do not apply when the operating voltage is changed from the factory setting.
- If water or other foreign objects enter the inside of the device, fire or electric shock may result.

Important Product Regulatory Information

EMC conformance testing is based on the use of supplied and recommended cable types. The use of other cable types may degrade EMC performance.

CE Notice

Hereby, Shure Incorporated declares that this product with CE Marking has been determined to be in compliance with European Union requirements.

The full text of the EU declaration of conformity is available at the following site: <https://www.shure.com/en-EU/support/declarations-of-conformity>.

UKCA Notice

Hereby, Shure Incorporated declares that this product with UKCA Marking has been determined to be in compliance with UK-CA requirements.

The full text of the UK declaration of conformity is available at the following site: <https://www.shure.com/en-GB/support/declarations-of-conformity>.

Cybersecurity STATEMENT OF COMPLIANCE

Product Type: Relevant connectable products defined as internet-connectable products or network-connectable products, in line with inter alia Product Security and Telecommunications Infrastructure Act 2022.

Manufacturer Statement: We, Shure Incorporated, certify and declare as manufacturer under our sole responsibility, that the above-mentioned product(s) conform(s) to the legislation as mentioned under Attachment 1 – to Cybersecurity Statement of Compliance listed here: <https://www.shure.com/en-GB/about-us/security>.

Information on how to report security issues: The latest version of Shure's Disclosure policy can be found at the following link: <https://www.shure.com/en-GB/about-us/security>

Security update periods: Shure provides support regarding hardware and software updates that continue the integral cyber security safety of Shure products up to 24 months after end of life (AEOL). For the full statement regarding Shure's product support policy, and information regarding products end of life status information can be found at the following link: <https://www.shure.com/en-GB/about-us/security>

Manufacturer:

Shure Incorporated 5800 Touhy Avenue
Niles, Illinois, 60714-4608 U.S.A. Website: www.Shure.com.

Technical documentation is kept at:

Shure Incorporated, Corporate Global Compliance Engineering Division

UK Importer/Representative:

Shure UK Limited
Unit 2, The IO Centre, Lea Road, Waltham Abbey, Essex, EN9 1AS, U.K.
Phone: +44 (0)1992 - 703058
Email: EMEAsupport@shure.de

On behalf of Manufacturer:

Chad Ayers
08 May 2025 Niles, Illinois
Senior Director, Global Compliance

FCC Notice

This equipment has been tested and found to comply with the limits for a Class B digital device pursuant to Part 15 of the FCC Rules. These limits are designed to provide reasonable protection against harmful interference when the equipment is operated in a residential installation. This equipment generates, uses, and can radiate radio frequency energy and, if not installed and used in accordance with the instructions, may cause harmful interference with radio communications. However, there is no guarantee that interference will not occur in a particular installation. If this equipment does cause harmful interference with radio or television reception, which can be determined by turning the equipment off and on, you are encouraged to try to correct the interference by one or more of the following measures:

- Reorient or relocate the antenna of the radio/television receiver.
- Increase the separation between this equipment and the radio/television receiver.
- Plug the equipment into a different outlet so that the equipment and the radio/television receiver are on different power mains branch circuits.
- Consult a representative of Shure or an experienced radio/television technician for additional suggestions.

This device complies with Part 15 of the FCC Rules. Operation is subject to the following two conditions:

1. This device may not cause harmful interference.
2. This device must accept any interference received, including interference that may cause undesired operation.

Notice: The FCC regulations provide that changes or modifications not expressly approved by Shure Incorporated could void your authority to operate this equipment.

For information regarding responsible party and other matters relating to FCC compliance, please contact Shure Incorporated, 5800 W. Touhy Avenue, Niles, Illinois 60714-4608 U.S.A. [shure.com/contact](https://www.shure.com/contact)

Canada, ISED Notice

Notice: The Industry Canada regulations provide that changes or modifications not expressly approved by Shure Inc. could void your authority to operate this equipment.

This Class B digital apparatus complies with Canadian ICES-003. Cet appareil numérique de la classe B est conforme à la norme NMB-003 du Canada.

Waste Electrical and Electronic Equipment (WEEE) Directive



In the European Union and the United Kingdom, this label indicates that this product should not be disposed of with household waste. It should be deposited at an appropriate facility to enable recovery and recycling.

Registration, Evaluation, Authorization of Chemicals (REACH) Directive

REACH (Registration, Evaluation, Authorization of Chemicals) is the European Union (EU) and the United Kingdom (UK) chemical substances regulatory framework. Information on substances of very high concern contained in Shure products in a concentration above 0.1% weight over weight (w/w) is available upon request.

Recycling Information

Please consider the environment, electric products and packaging are part of regional recycling schemes and do not belong to regular household waste.

Introduction to EMC

Electromagnetic Interference (EMI) is any signal or emission, radiated in free space or conducted along power or signal leads, that endangers the functioning of radio navigation or other safety service or seriously degrades, obstructs, or repeatedly interrupts a licensed radio communications service. Radio communications services include but are not limited to AM/FM commercial broadcast, television, cellular services, radar, air-traffic control, pager, and Personal Communication Services (PCS). These licensed radio services, and unlicensed radio services, such as WLAN, ZIGBEE or Bluetooth, along with unintentional radiators such as digital devices contribute to the electromagnetic environment.

Electromagnetic Compatibility (EMC) is the ability of items of electronic equipment to function properly together in the electronic environment. While this equipment has been designed and determined to be compliant with regulatory agency limits for EMI, there is no guarantee that interference will not occur in a particular installation.

Shure products are designed, tested, and classified for their intended electromagnetic environment. These electromagnetic environment classifications generally refer to the following harmonized definitions:

- Class B products are intended for use in residential/domestic environments but may also be used in non-residential/non-domestic environments.

Note: The residential/domestic environment is an environment where the use of broadcast radio and television receivers may be expected within a distance of 10 m from where this product is used.

- Class A products are intended for use in non-residential/non-domestic environments. Class A products may also be utilized in residential/domestic environments but may cause interference and require the user to take adequate corrective measures.

Regulatory Model Number (RMN)

For regulatory identification purposes your product has been assigned a regulatory model number (RMN). This regulatory model number should not be confused with product number, as below.

RMN: MXA320	Product Numbers: MXA320W, MXA320B, MXA320AL
--------------------	--