

WARNING!!! HANGING LOUDSPEAKERS IS A SERIOUS UNDERTAKING THAT SHOULD BE DONE ONLY BY QUALIFIED AND EXPERIENCED PERSONNEL. CHECK WITH AN ARCHITECT OR STRUCTURAL ENGINEER TO VERIFY ANY BUILDING ATTACHMENT POINTS. RENKUS-HEINZ IS NOT RESPONSIBLE FOR ANY NON-RENKUS-HEINZ PRODUCTS OR FOR ANY MISUSE OF RENKUS-HEINZ PRODUCTS.

NOTES:

1. REFERENCE EEE-ICC12/3-RD-1 B.O.M. FOR ASSEMBLY DETAILS.
2. COMPONENT LEVEL DRAWINGS AVAILABLE UPON REQUEST.
- 2.1. AUTOCAD FILES AND SOLIDWORKS MODELS AVAILABLE.

BILL OF MATERIALS		
PART NUMBER	DESCRIPTION	QUANTITY
622-MET116	WALL MOUNT BRACKET	1
622-MET117	WALL HINGE BRACKET	1
622-MET202	INPUT PANEL COVER PLATE	1
622-MET207	PCX4 ENCLOSURE	1
622-WS0151	M6 x 1 mm x 14 mm FLAT HEAD PHILLIPS SCREW McMasterCarr PN: 91420A425	3
622-WSS0054	#6-32x3/8 PHILLIPS FLAT HEAD SCREW McMasterCarr PN: 91771A146	8
622-WNS0044	M10 x 1.5 mm SERRATED FLANGE LOCKNUT McMasterCarr PN: 97400A103	2
622-WSS0280	M3 x 0.5 mm x 10 mm PHILLIPS FLAT HEAD SCREWS	4

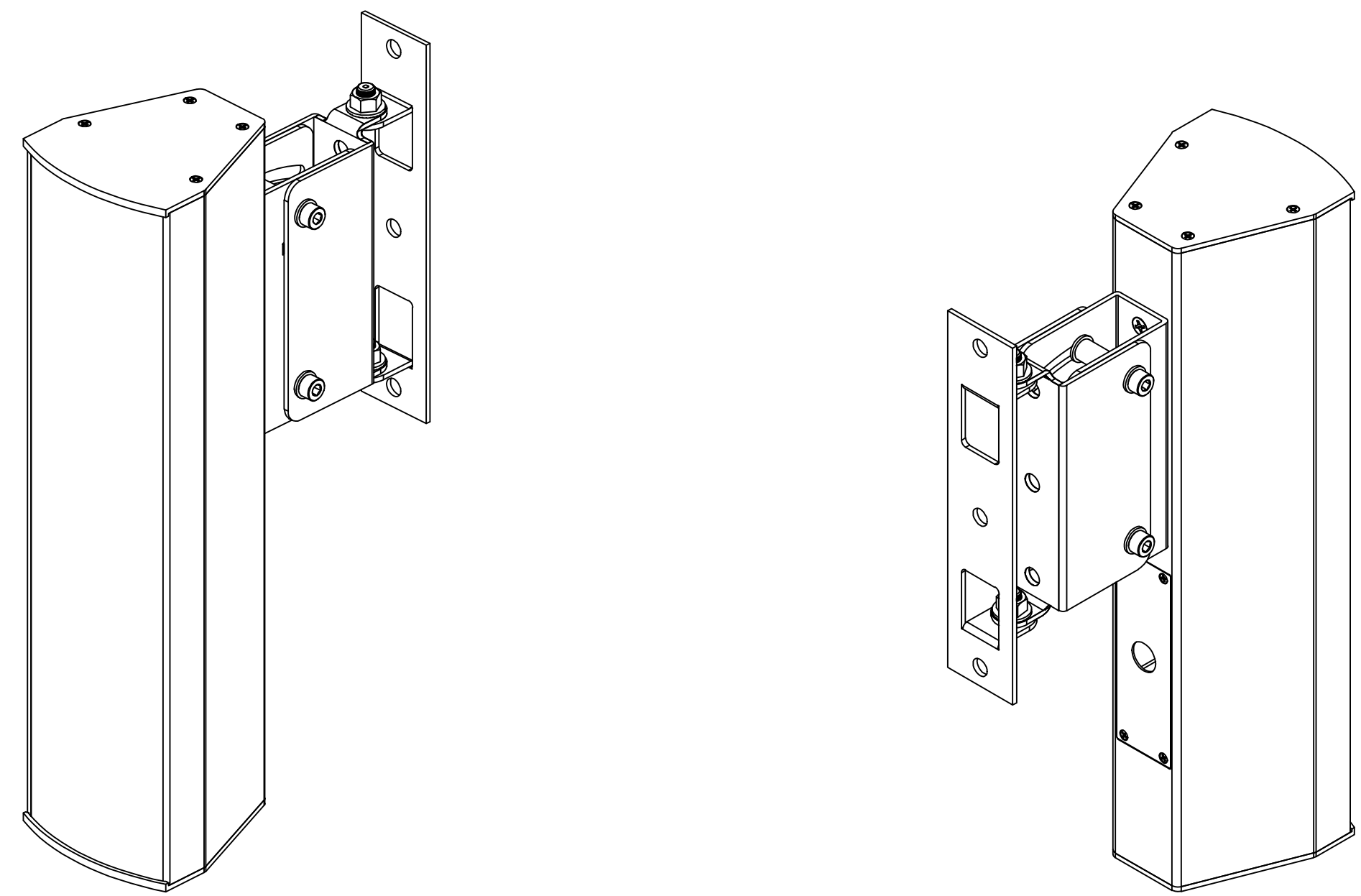
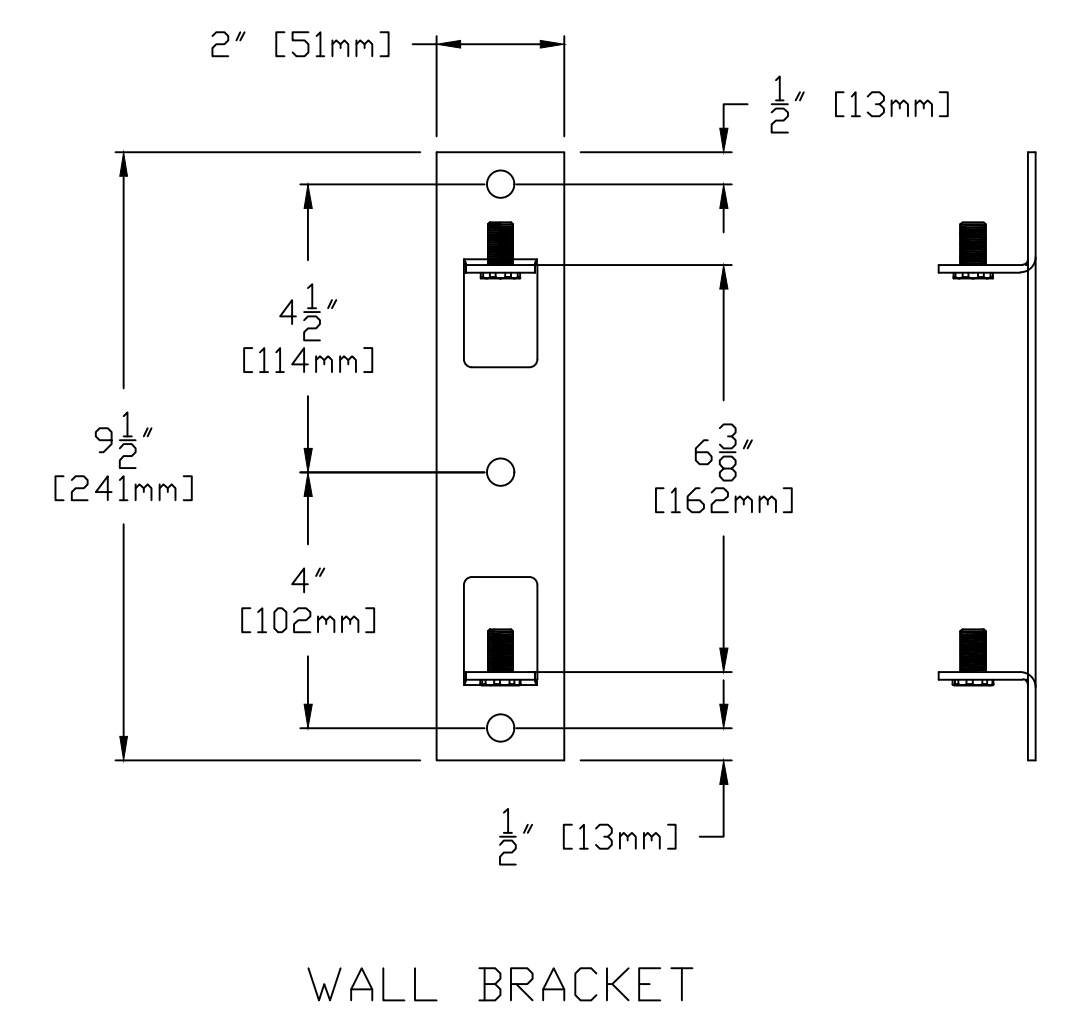
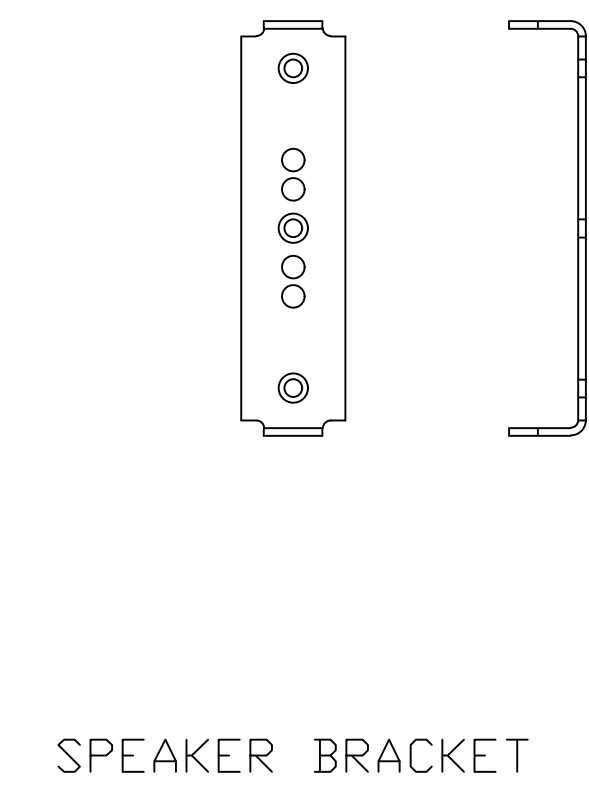
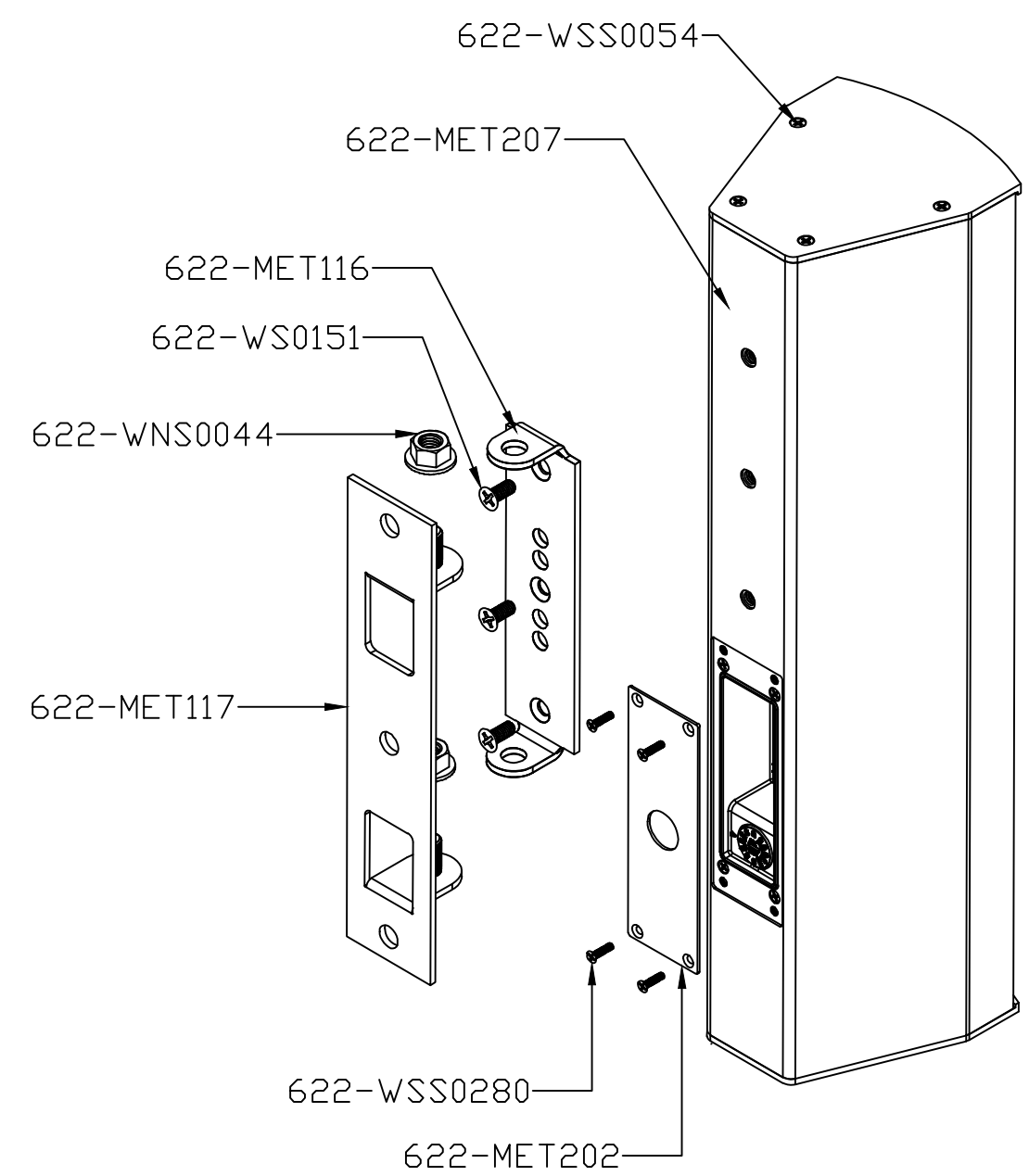
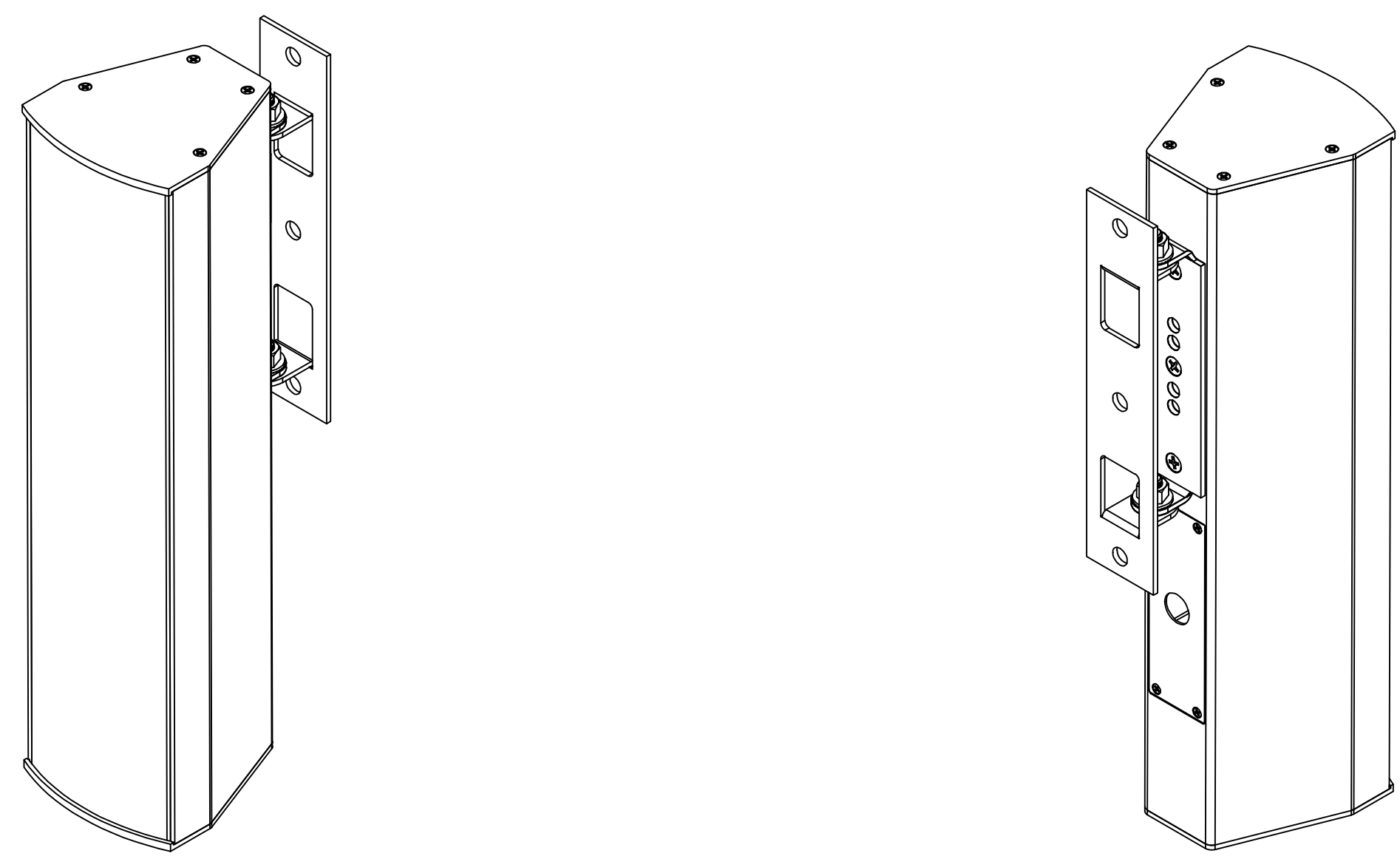

UBX4 WITH PAN & TILT BRACKET ASSEMBLY

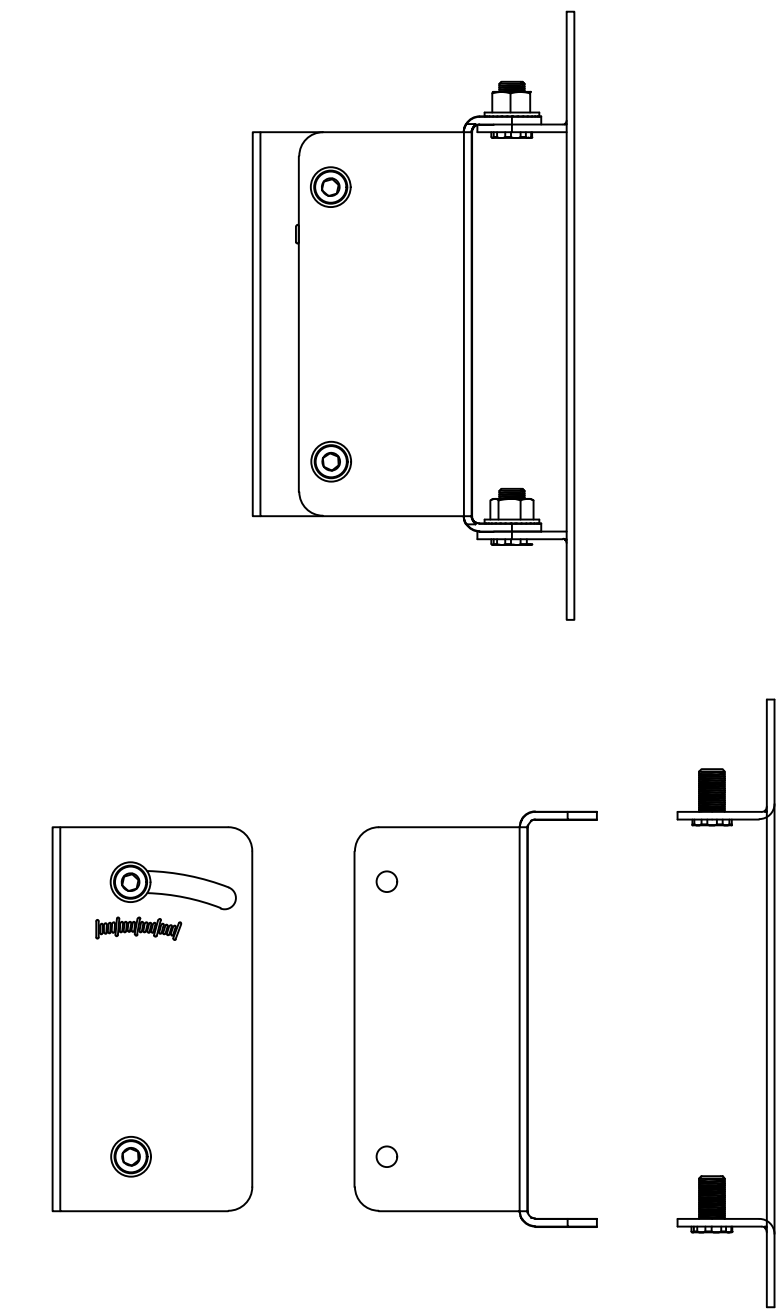
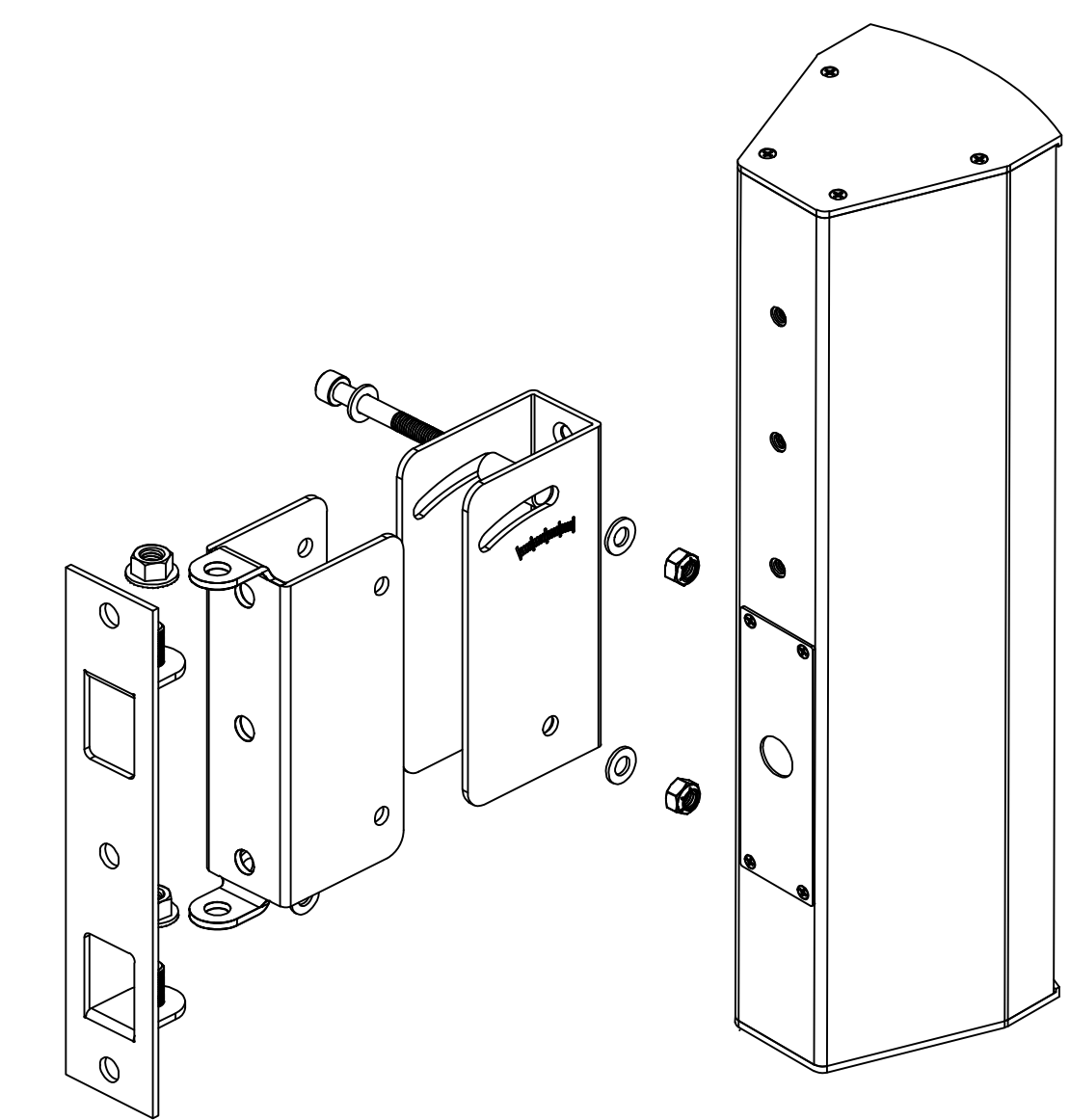

PAN & TILT BRACKET

THE MATERIAL CONTAINED HEREIN IS PROPRIETARY TO RENKUS-HEINZ AND SHALL NOT BE REPRODUCED DISCLOSED OR USED FOR ANY OTHER PURPOSE WITHOUT THE WRITTEN APPROVAL OF RENKUS-HEINZ.

ECO	REV	DESCRIPTION	DATE	BY
8983	B	PCX SERIES NOMENCLATURE SWITCH TO 'UBX'; UNI-BEAM PASSIVE.	11/11/22	C.D.

UNLESS OTHERWISE SPECIFIED DIMENSIONS ARE IN INCHES TOLERANCES ARE:		INTL	DATE
DECIMALS	ANGLES	DL	05/09/22
.XX± .01	±0° 30"		
.XXX±.005			

DRAWN	CHECK	DESIGN	ENG	APPROV	APPROV

REF DWG:	SIZE	CODE IDENT	DWG NO.	REV
W/W-RH921	D			B

NEXT ASSY.	USED ON	DO NOT SCALE DRAWING	SCALE: 1 = 3	WEIGHT:	SHEET 1 OF 2

THE MATERIAL CONTAINED HEREIN IS PROPRIETARY TO RENKUS-HEINZ AND SHALL NOT BE REPRODUCED DISCLOSED OR USED FOR ANY OTHER PURPOSE WITHOUT THE WRITTEN APPROVAL OF RENKUS-HEINZ.

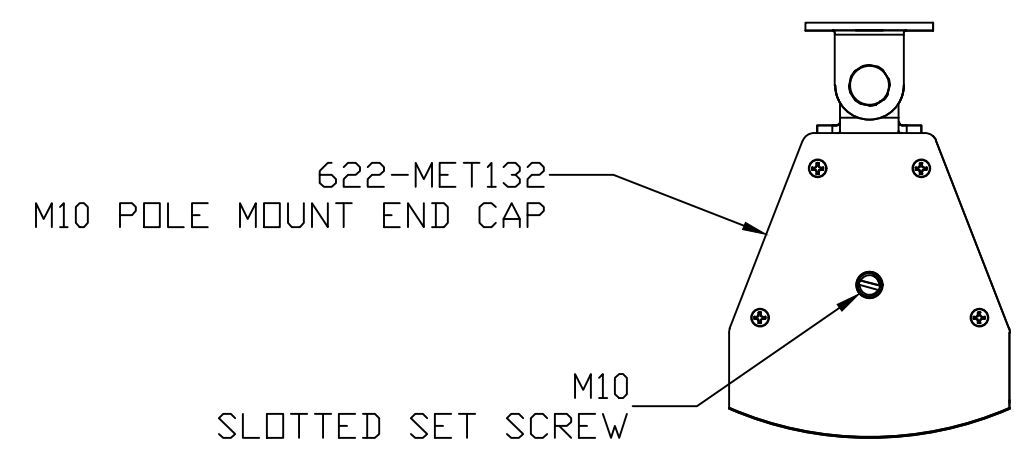
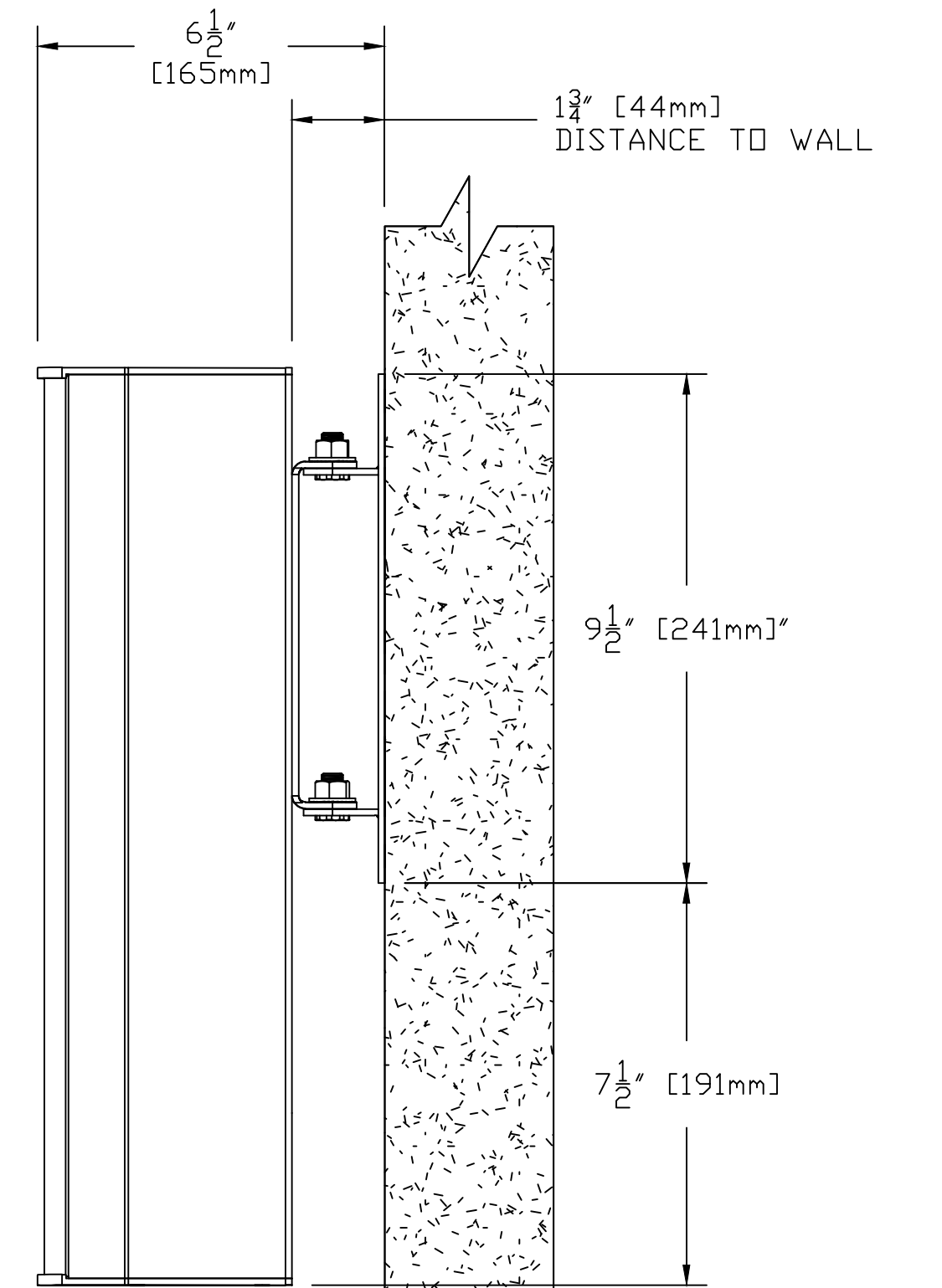
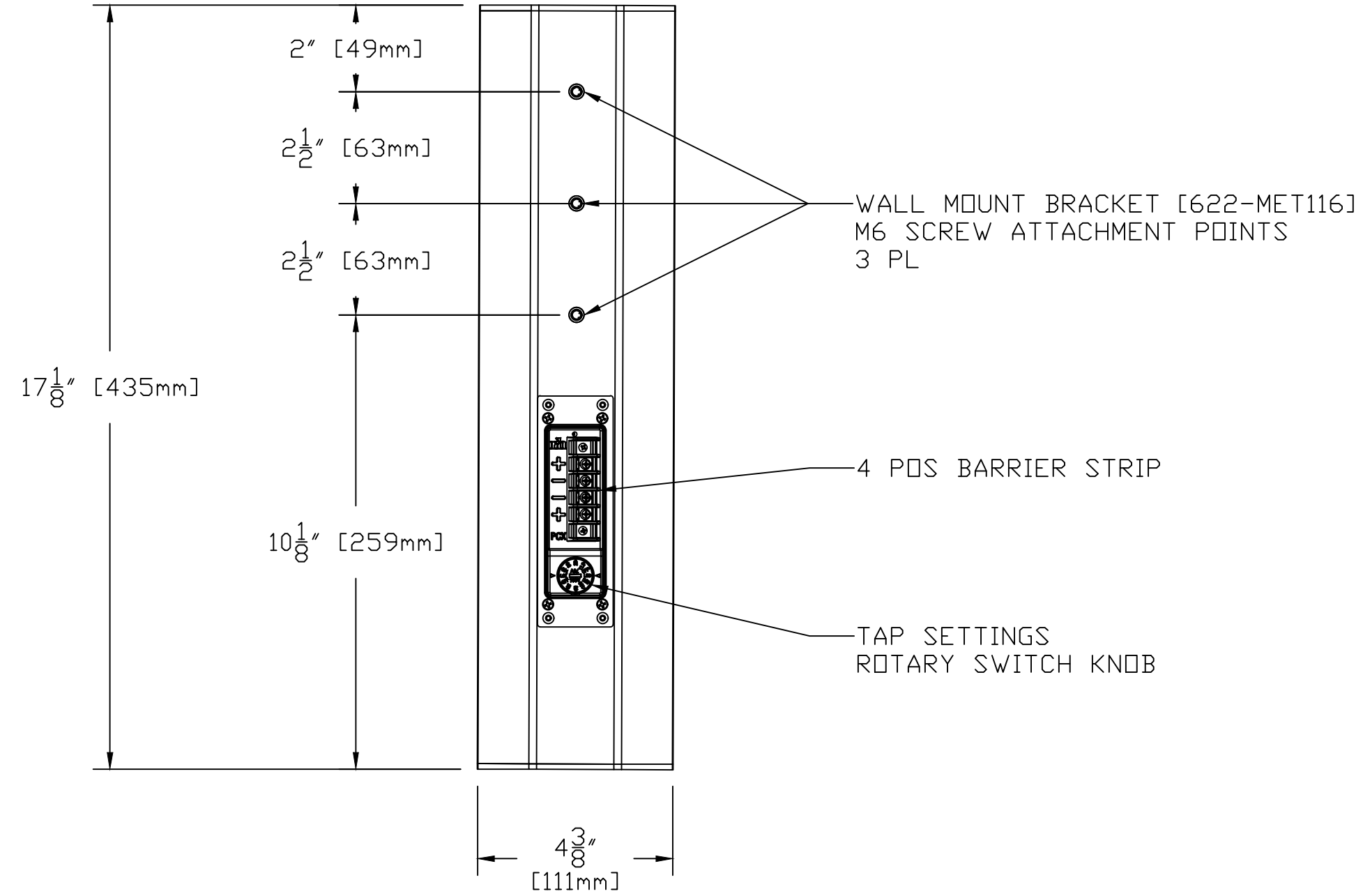
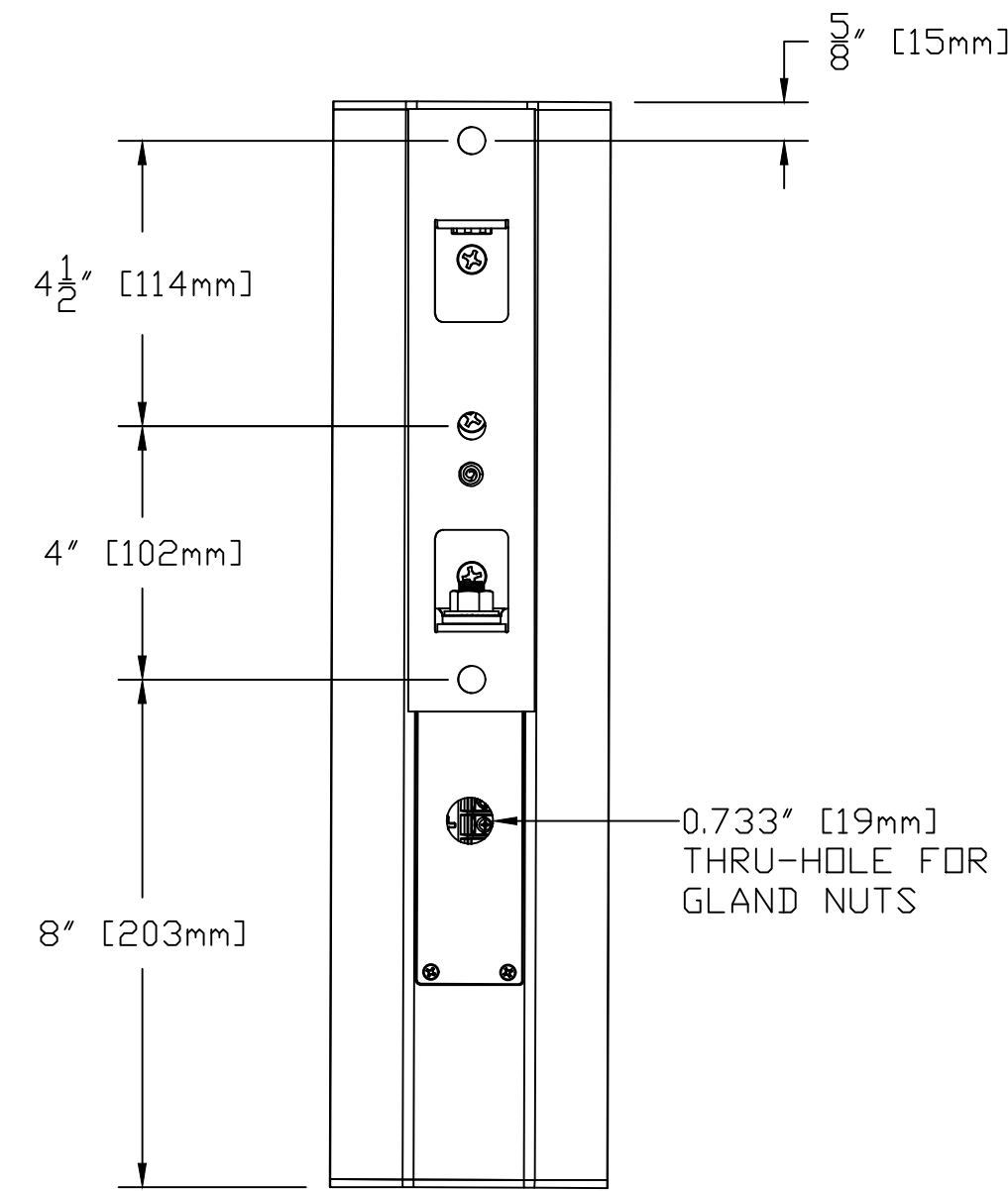
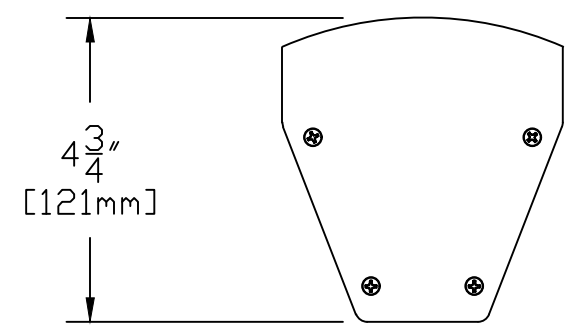
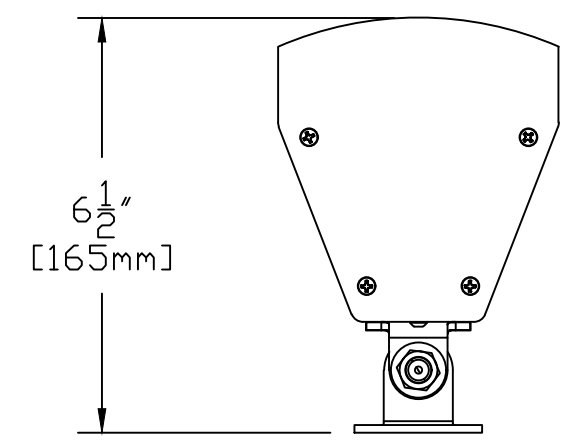
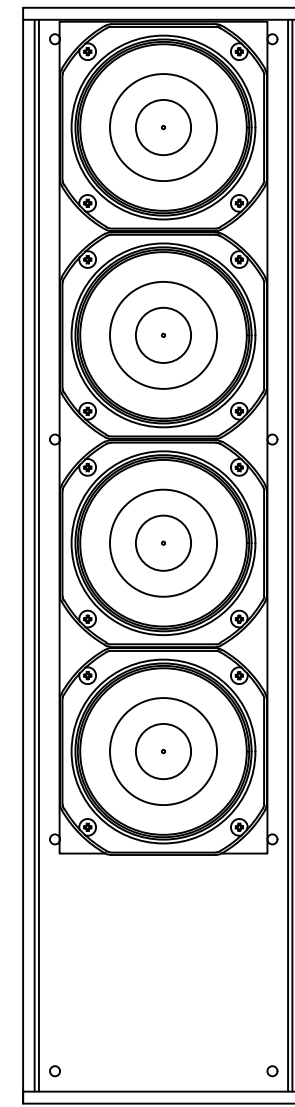
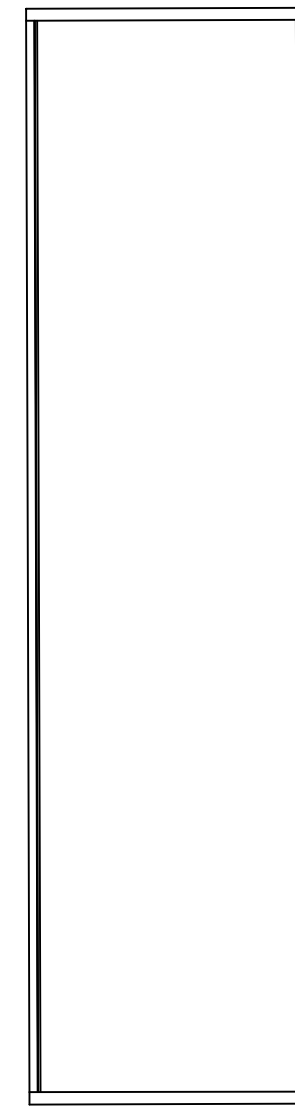

WALL MOUNT PANNING RANGE

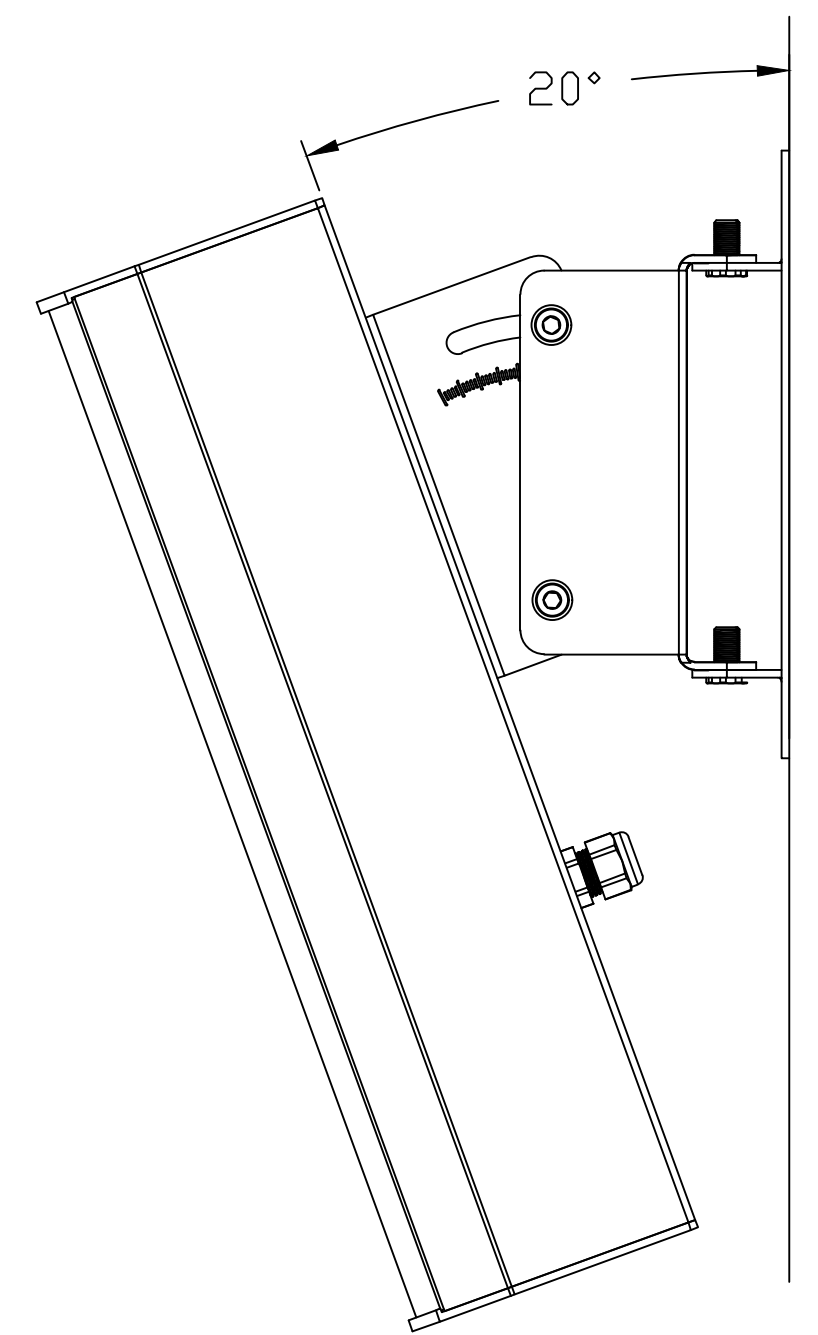
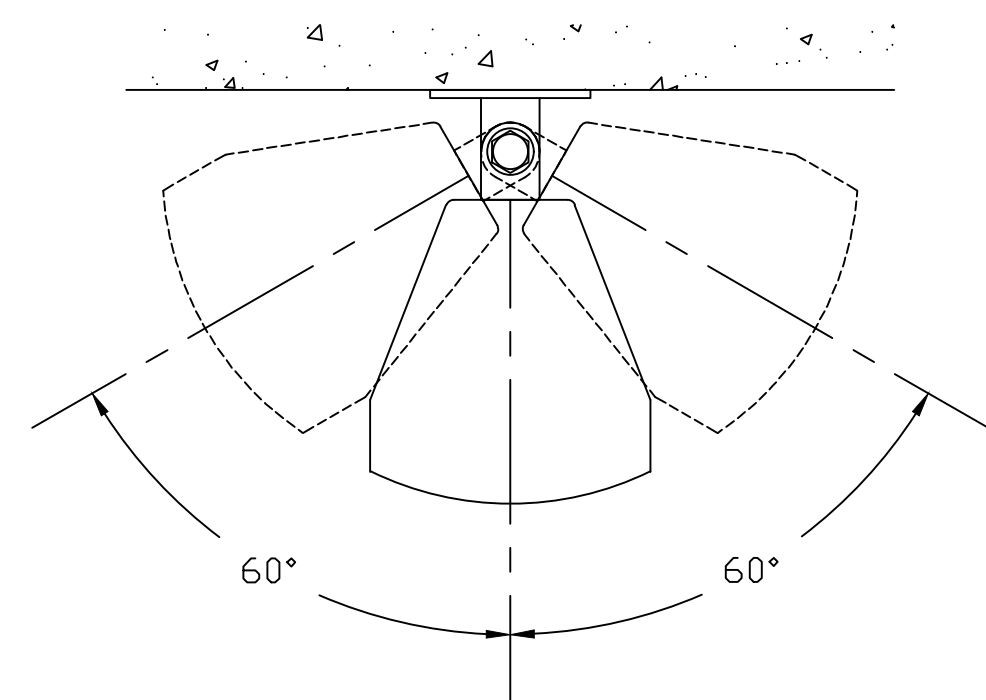

UBX4 TILT RANGE

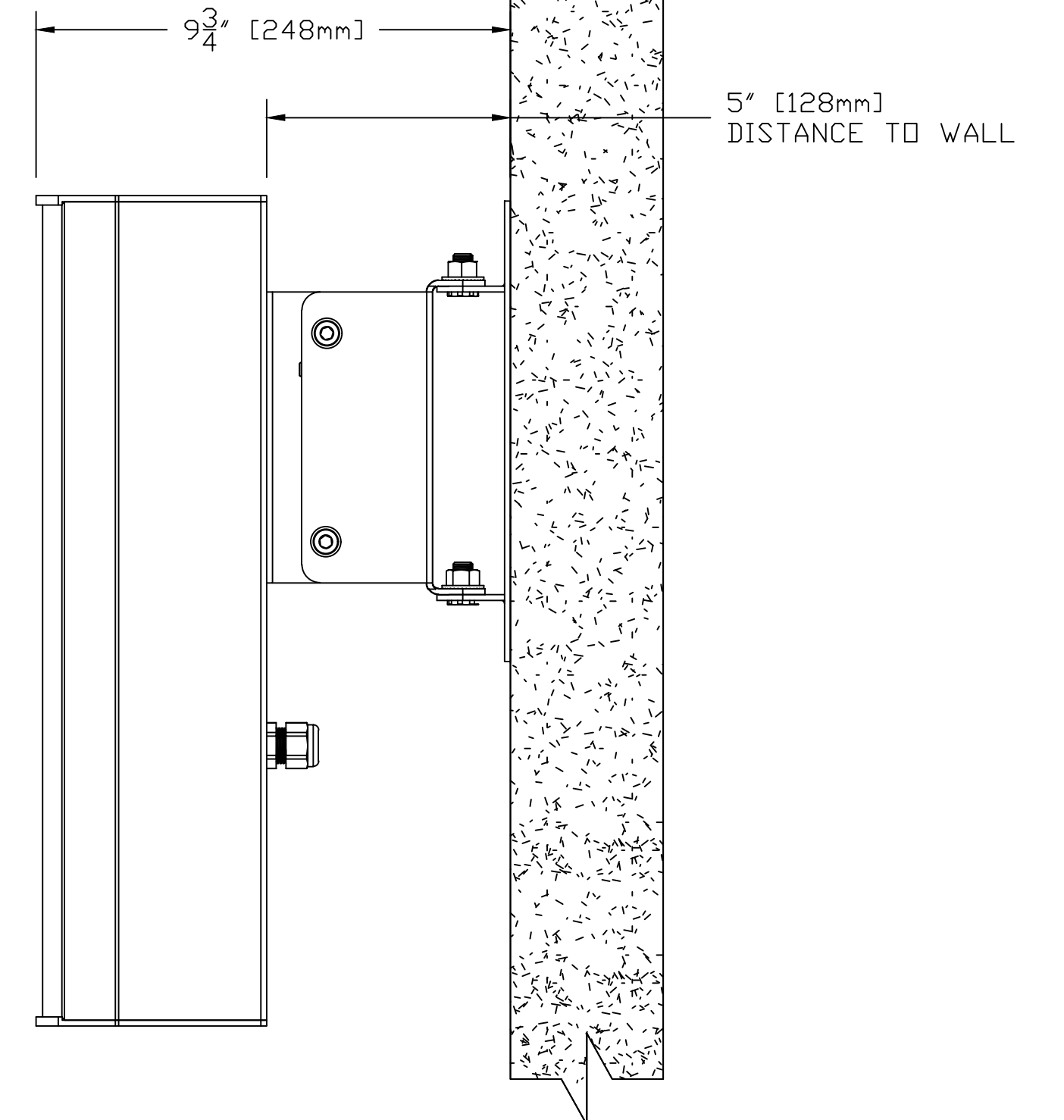

UNLESS OTHERWISE SPECIFIED DIMENSIONS ARE IN INCHES TOLERANCES ARE:		INTL	DATE	
DECIMALS	ANGLES	DL	05/09/22	
.XX± .01	±0° 30"			TITLE: W/W-RH 921 UBX4 ASSEMBLY
.XXX±.005				SIZE D CODE IDENT DWG NO. REV B
				SCALE: 1 = 3 WEIGHT: SHEET 2 OF 2