

WARNING!!! HANGING LOUDSPEAKERS IS A SERIOUS UNDERTAKING THAT SHOULD BE DONE ONLY BY QUALIFIED AND EXPERIENCED PERSONNEL. CHECK WITH AN ARCHITECT OR STRUCTURAL ENGINEER TO VERIFY ANY BUILDING ATTACHMENT POINTS. RENKUS-HEINZ IS NOT RESPONSIBLE FOR ANY NON-RENKUS-HEINZ PRODUCTS OR FOR ANY MISUSE OF RENKUS-HEINZ PRODUCTS.

NOTES:

1. REFERENCE EEE-ICC12/3-RD-1 B.O.M. FOR ASSEMBLY DETAILS.
2. COMPONENT LEVEL DRAWINGS AVAILABLE UPON REQUEST.
- 2.1. AUTOCAD FILES AND SOLIDWORKS MODELS AVAILABLE.

BILL OF MATERIALS		
PART NUMBER	DESCRIPTION	QUANTITY
622-MET116	WALL MOUNT BRACKET	1
622-MET117	WALL HINGE BRACKET	1
622-MET202	INPUT PANEL COVER PLATE	1
622-MET209	PCX16 ENCLOSURE	1
622-WS0151	M6 x 1 mm x 14 mm FLAT HEAD PHILLIPS SCREW McMasterCarr PN: 91420A425	3
622-WSS0054	#6-32x3/8 PHILLIPS FLAT HEAD SCREW McMasterCarr PN: 91771A146	8
622-WNS0044	M10 x 1.5 mm SERRATED FLANGE LOCKNUT McMasterCarr PN: 97400A103	2
622-WSS0280	M3 x 0.5 mm x 10 mm PHILLIPS FLAT HEAD SCREWS	4

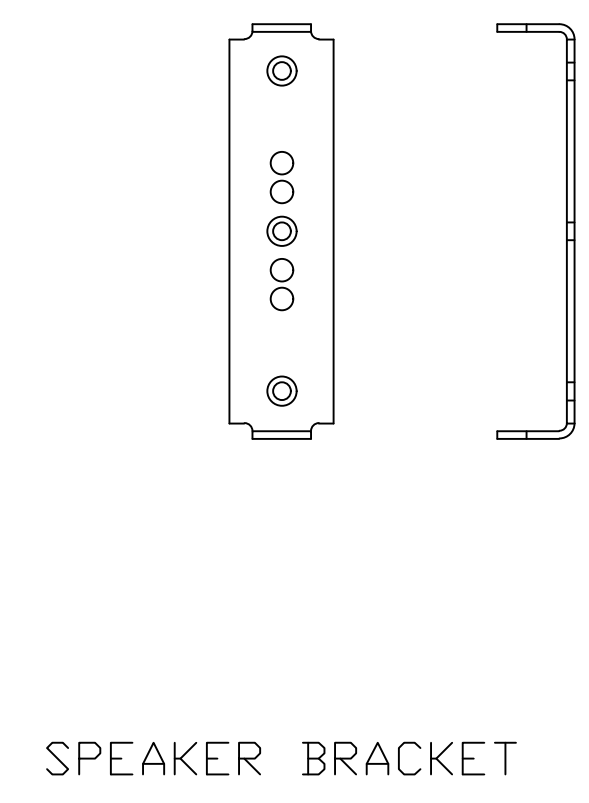
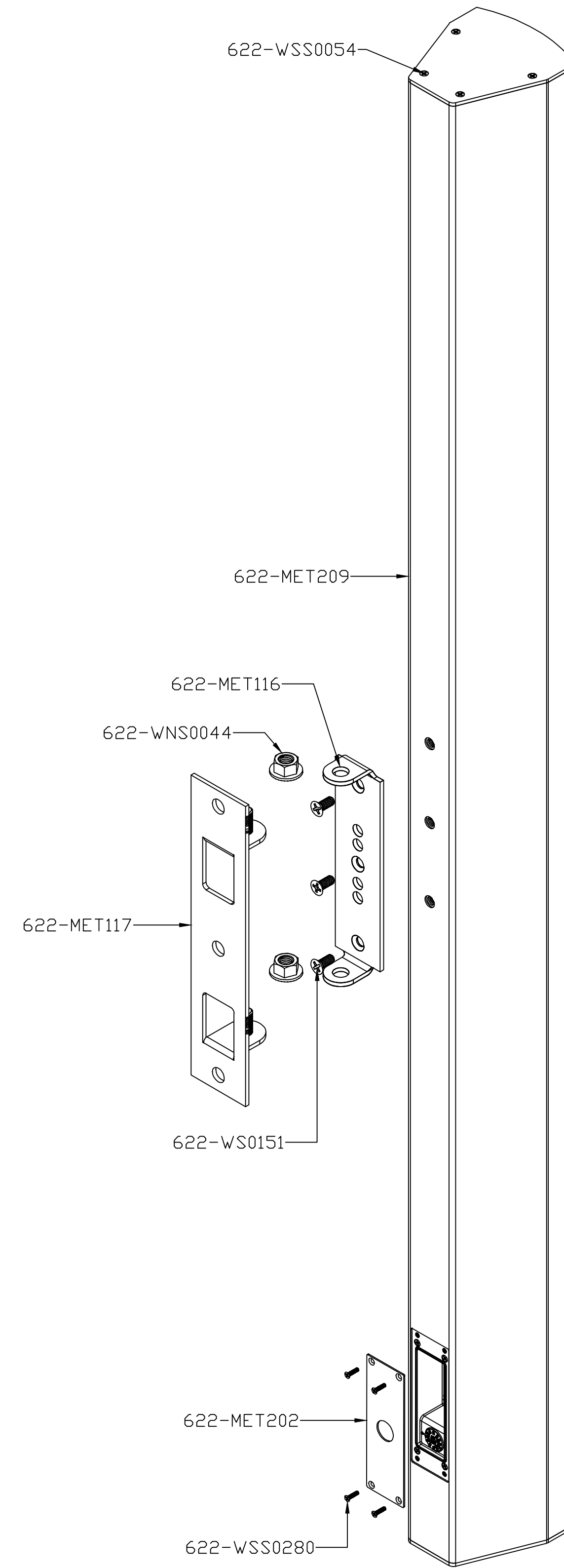
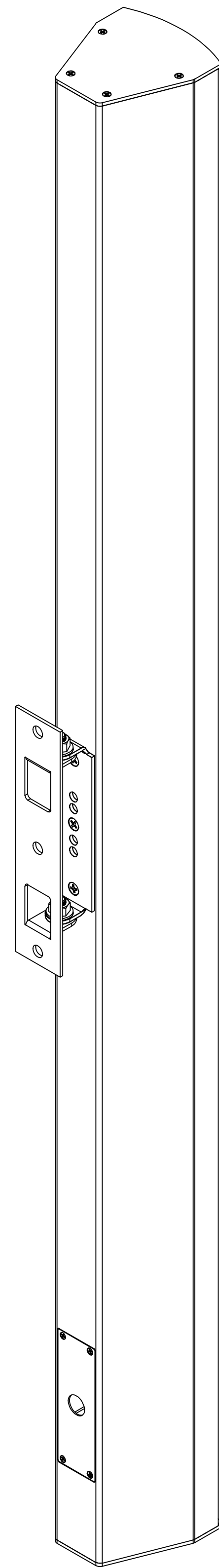
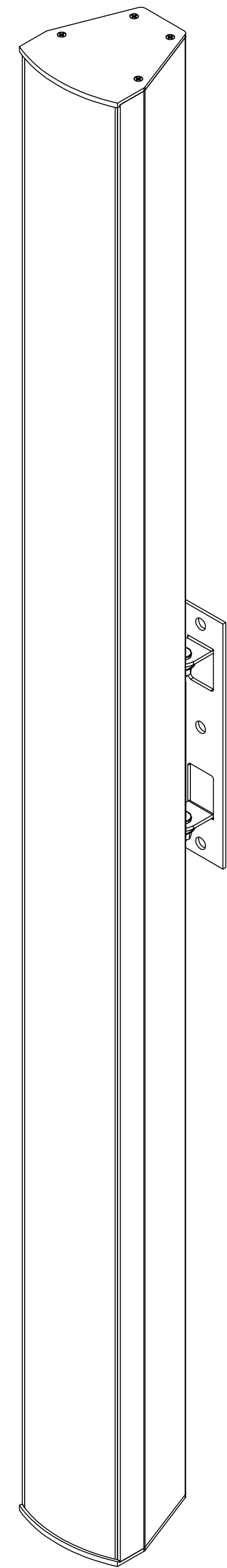

SPEAKER BRACKET

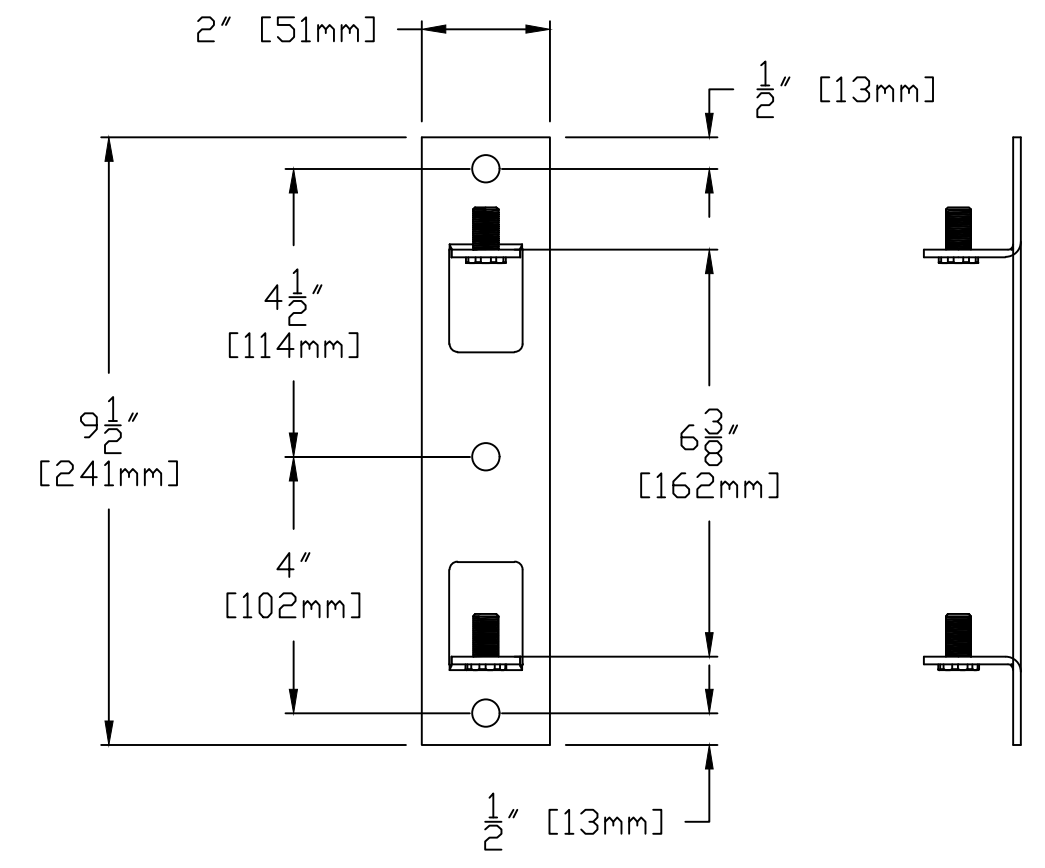

WALL BRACKET

THE MATERIAL CONTAINED HEREIN IS PROPRIETARY TO RENKUS-HEINZ AND SHALL NOT BE REPRODUCED DISCLOSED OR USED FOR ANY OTHER PURPOSE WITHOUT THE WRITTEN APPROVAL OF RENKUS-HEINZ.

ECO	REV	DESCRIPTION	DATE	BY
8983	B	PCX SERIES NOMENCLATURE SWITCH TO 'UBX'; UNI-BEAM PASSIVE.	11/11/22	C.D.

UNLESS OTHERWISE SPECIFIED DIMENSIONS ARE IN INCHES TOLERANCES ARE:		INTL	DATE	 <b>RENKUS-HEINZ, inc.</b>
DRAWN	DL	05/09/22		
CHECK				
DESIGN				
ENG				
APPROV				TITLE: WwW-RH 923 UBX16 ASSEMBLY
APPROV				REF DWG: WwW-RH923
NEXT ASSY.	USED ON	DO NOT SCALE DRAWING	SIZE D	CODE IDENT DWG NO.
APPLICATION	DEBURR AND REMOVE SHARP EDGES	SCALE: 1 = 3	WEIGHT:	REV B

THE MATERIAL CONTAINED HEREIN IS PROPRIETARY TO RENKUS-HEINZ AND SHALL NOT BE REPRODUCED DISCLOSED OR USED FOR ANY OTHER PURPOSE WITHOUT THE WRITTEN APPROVAL OF RENKUS-HEINZ.

WARNING!!! HANGING LOUDSPEAKERS IS A SERIOUS UNDERTAKING THAT SHOULD BE DONE ONLY BY QUALIFIED AND EXPERIENCED PERSONNEL. CHECK WITH AN ARCHITECT OR STRUCTURAL ENGINEER TO VERIFY ANY BUILDING ATTACHMENT POINTS. RENKUS-HEINZ IS NOT RESPONSIBLE FOR ANY NON-RENKUS-HEINZ PRODUCTS OR FOR ANY MISUSE OF RENKUS-HEINZ PRODUCTS.

NOTES:

1. REFERENCE EEE-ICC12/3-RD-1 B.O.M. FOR ASSEMBLY DETAILS.
2. COMPONENT LEVEL DRAWINGS AVAILABLE UPON REQUEST.
- 2.1. AUTOCAD FILES AND SOLIDWORKS MODELS AVAILABLE.

BILL OF MATERIALS		
PART NUMBER	DESCRIPTION	QUANTITY
622-MET116	WALL MOUNT BRACKET	1
622-MET117	WALL HINGE BRACKET	1
622-MET202	INPUT PANEL COVER PLATE	1
622-MET209	PCX16 ENCLOSURE	1
622-WS0151	M6 x 1 mm x 14 mm FLAT HEAD PHILLIPS SCREW McMasterCarr PN: 91420A425	3
622-WSS0054	#6-32x3/8 PHILLIPS FLAT HEAD SCREW McMasterCarr PN: 91771A146	8
622-WNS0044	M10 x 1.5 mm SERRATED FLANGE LOCKNUT McMasterCarr PN: 97400A103	2
622-WSS0280	M3 x 0.5 mm x 10 mm PHILLIPS FLAT HEAD SCREWS	4

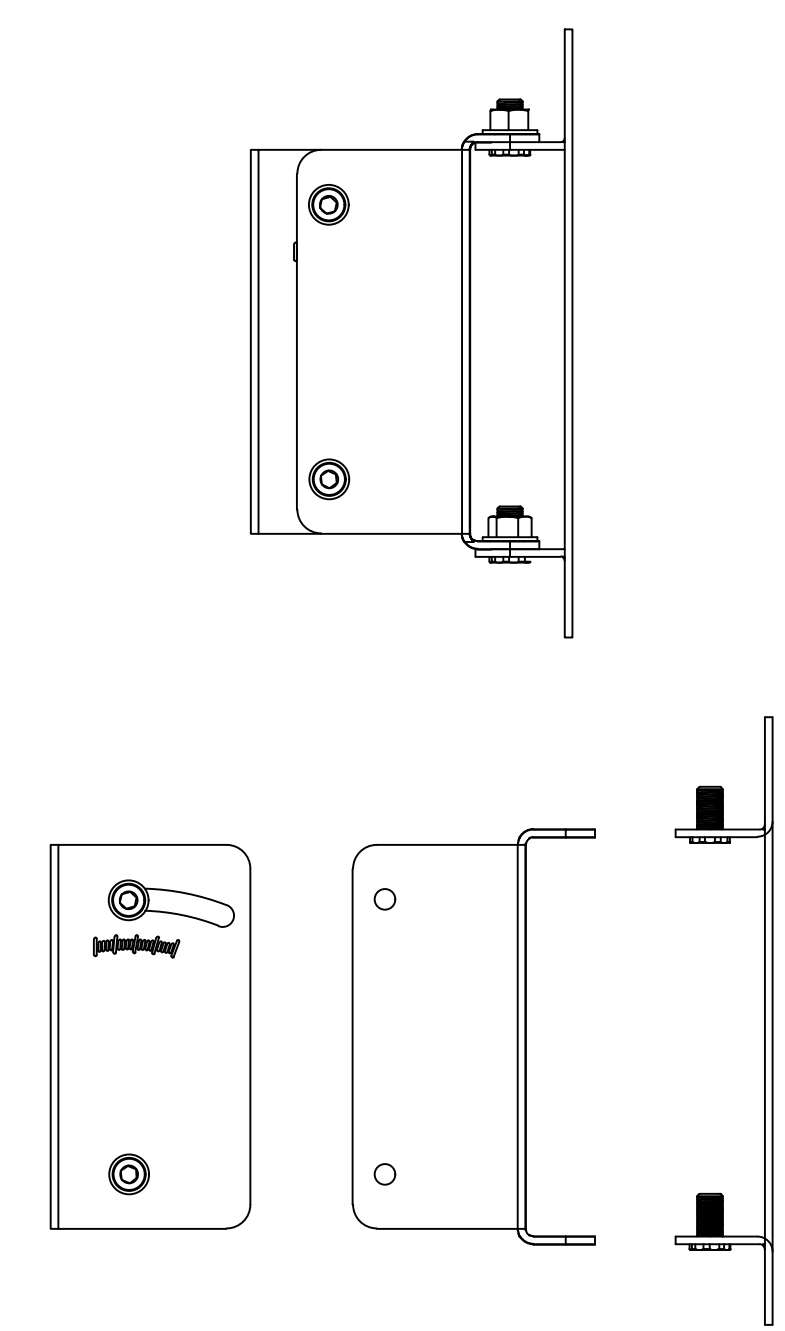
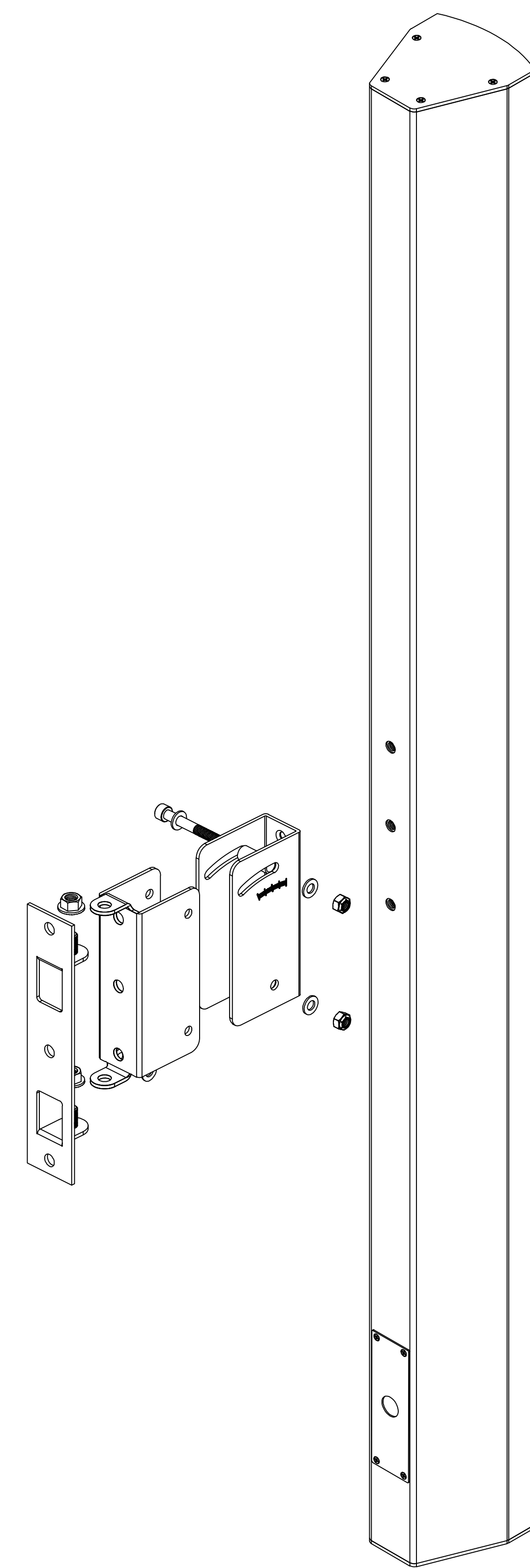
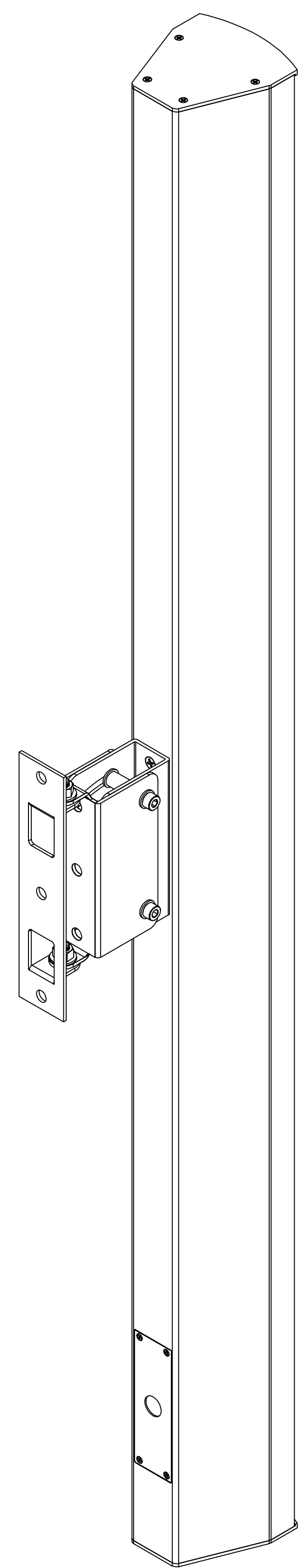
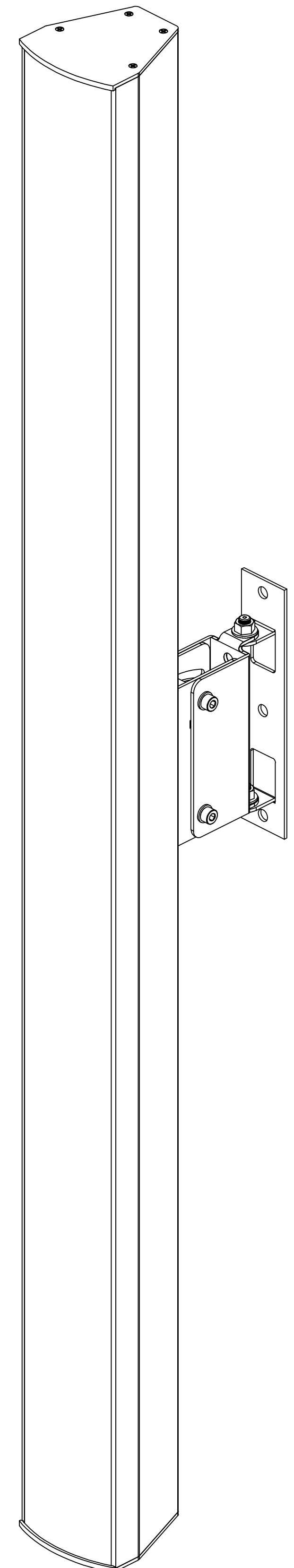

PAN & TILT BRACKET

UBX16 WITH PAN & TILT BRACKET ASSEMBLY

THE MATERIAL CONTAINED HEREIN IS PROPRIETARY TO RENKUS-HEINZ AND SHALL NOT BE REPRODUCED DISCLOSED OR USED FOR ANY OTHER PURPOSE WITHOUT THE WRITTEN APPROVAL OF RENKUS-HEINZ.

ECO	REV	DESCRIPTION	DATE	BY
8983	B	PCX SERIES NOMENCLATURE SWITCH TO 'UBX'; UNI-BEAM PASSIVE.	11/11/22	C.D.

UNLESS OTHERWISE SPECIFIED DIMENSIONS ARE IN INCHES TOLERANCES ARE: DECIMALS .XX± .01 .XXX±.005	DRAWN	INTL	DATE
	CHECK	DL	05/09/22
	DESIGN		
	ENG		
	APPROV		

  

TITLE: WwW-RH 923 UBX16 ASSEMBLY	
REF DWG: WwW-RH923	SIZE: D
NEXT ASSY. USED ON APPLICATION	DO NOT SCALE DRAWING

THE MATERIAL CONTAINED HEREIN IS PROPRIETARY TO RENKUS-HEINZ AND SHALL NOT BE REPRODUCED DISCLOSED OR USED FOR ANY OTHER PURPOSE WITHOUT THE WRITTEN APPROVAL OF RENKUS-HEINZ.	SCALE: 1 = 3	WEIGHT:	SHEET 2 OF 4
--	--------------	---------	--------------



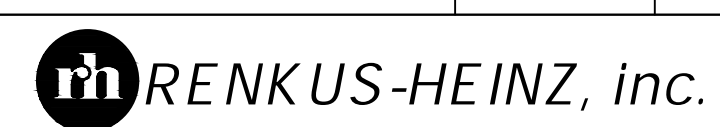

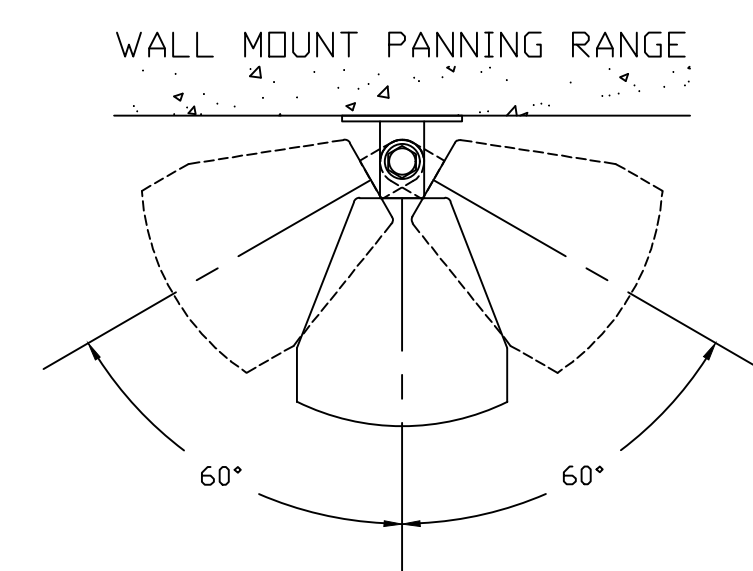
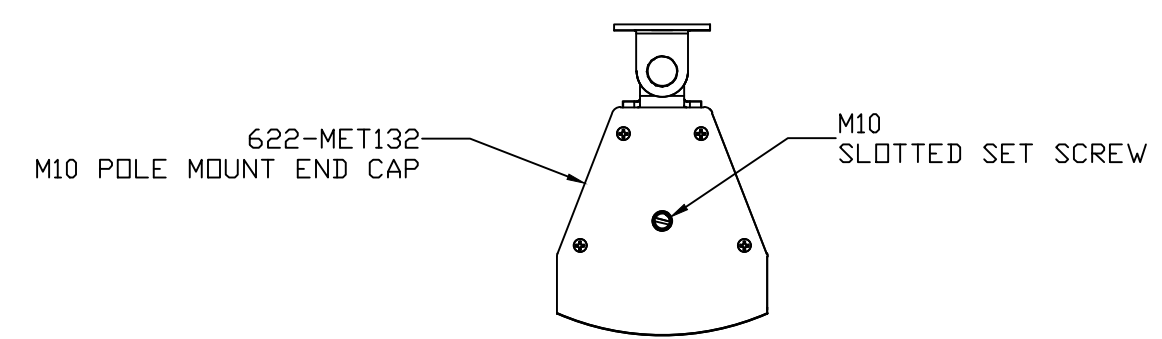
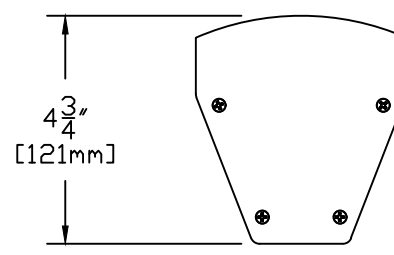
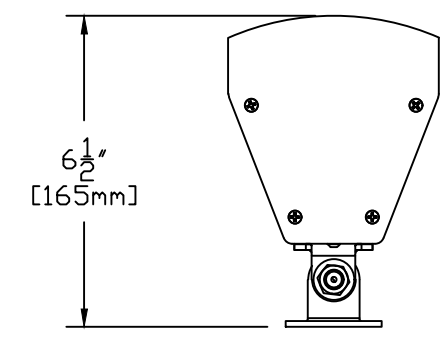
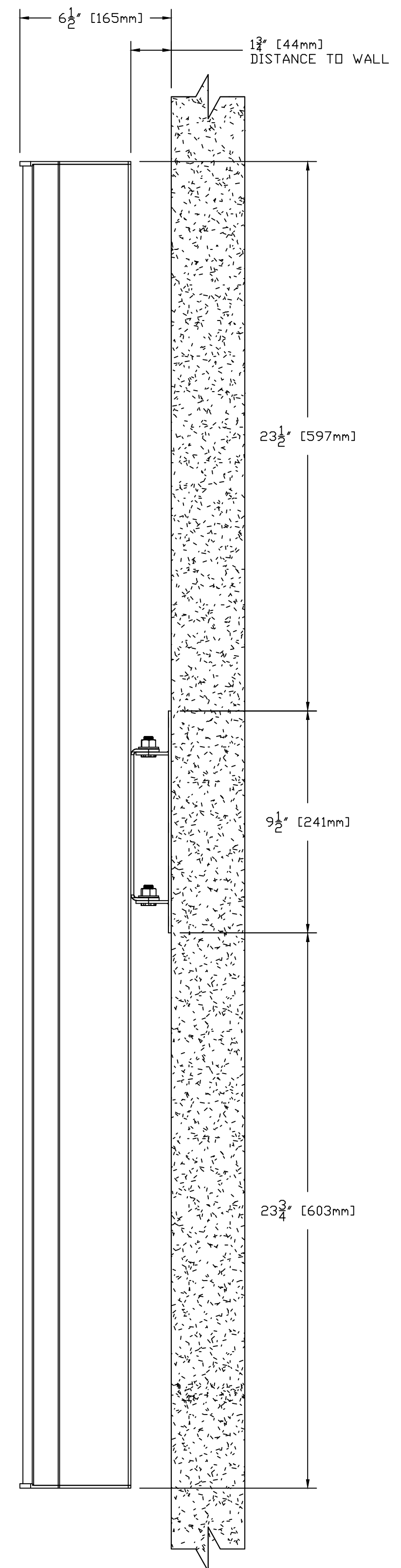
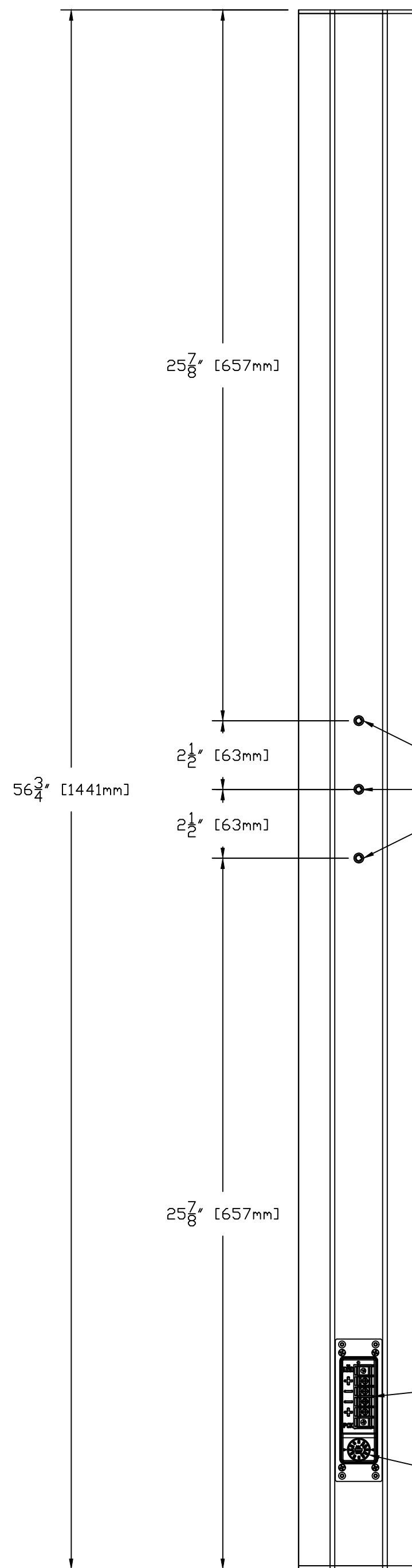
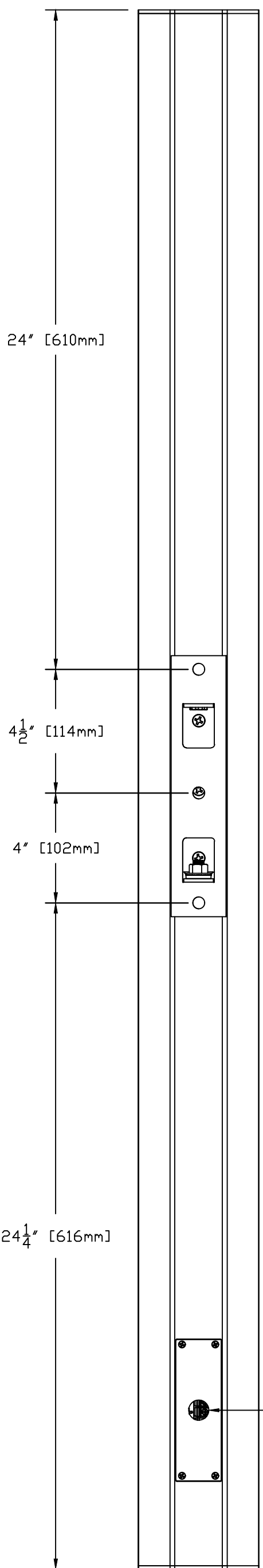
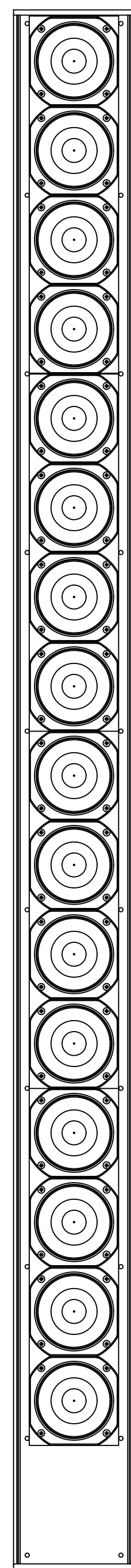
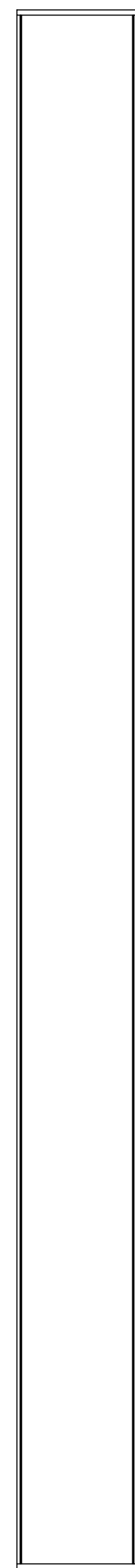
UNLESS OTHERWISE SPECIFIED DIMENSIONS ARE IN INCHES TOLERANCES ARE:		INTL	DATE
DECIMALS	ANGLES	DRAWN	DL
.XX± .01	±0° 30"	CHECK	05/09/22
.XXX±.005		DESIGN	
		ENG	
		APPROV	
		APPROV	
		REF DWG:	
		WW-RH923	
NEXT ASSY.	USED ON	DO NOT SCALE DRAWING	
APPLICATION	DEBURR AND REMOVE SHARP EDGES	SCALE: 1 = 4	WEIGHT:

<b>RENKUS-HEINZ, inc.</b>			
TITLE: WW-RH 923 UBX16 ASSEMBLY			
SIZE	CODE IDENT	DWG NO.	REV
D			B
SCALE: 1 = 4			SHEET 3 OF 4

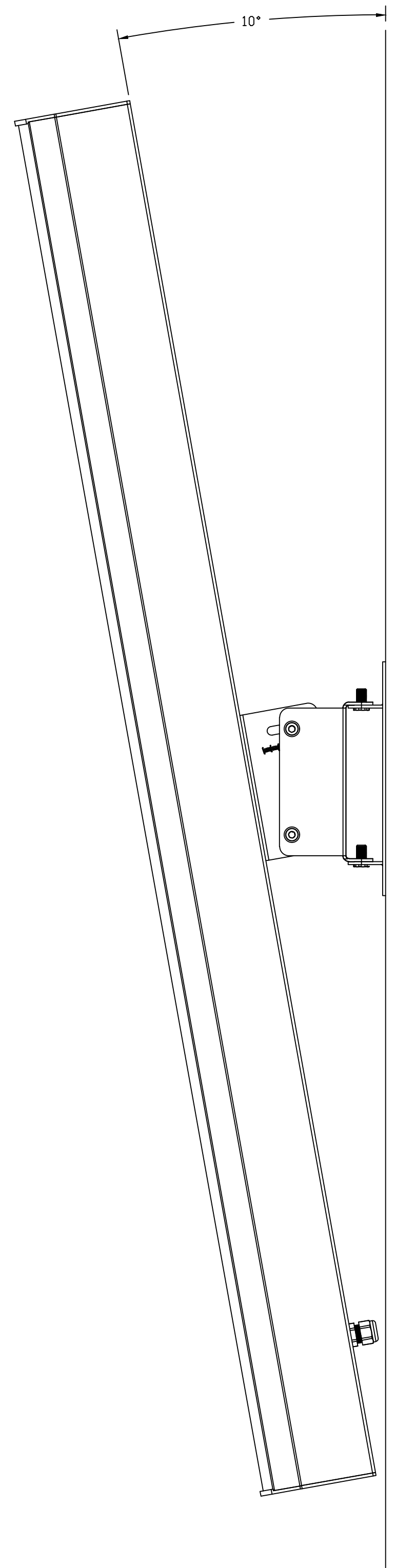

UBX16 TILT RANGE

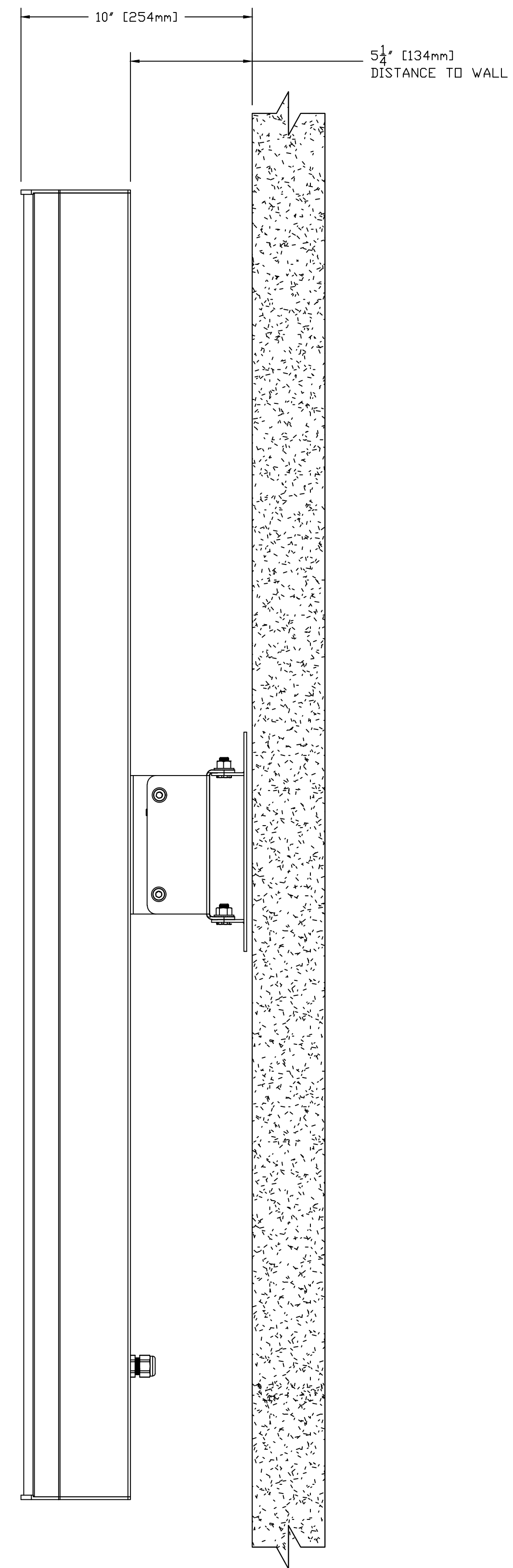

UNLESS OTHERWISE SPECIFIED DIMENSIONS ARE IN INCHES TOLERANCES ARE:		INTL	DATE	
DECIMALS	ANGLES	DL	05/09/22	
.XX± .01	±0° 30"			TITLE:
.XXX±.005				Ww-RH 923 UBX16 ASSEMBLY
				SIZE
				D
				CODE IDENT
				DWG NO.
				REV
				B
NEXT ASSY.	USED ON	DO NOT SCALE DRAWING		SCALE: 1 = 4
APPLICATION	DEBURR AND REMOVE SHARP EDGES	WEIGHT:		SHEET 4 OF 4